

Christiani

Your Partner for Technical Education

■ School ■ Vocational Training ■ University ■ Further Training

**Technical Institute for
Vocational Training**

SINCE 1931

Automotive Technology 2017

Technical Training



christiani-tvet.com

85
Years of
technical
education



Christiani – Your Partner for Technical Education



85

Years of
technical
education

1931 – 2016

■ Our competences

Christiani provides teaching and learning materials for almost all conceivable requirements of technical education - and this for all ages and stages of life. With this integrated approach, we support lifelong learning. Our customers benefit from this complete package and can always resort on the latest teaching and learning materials to convey knowledge soundly and practically.

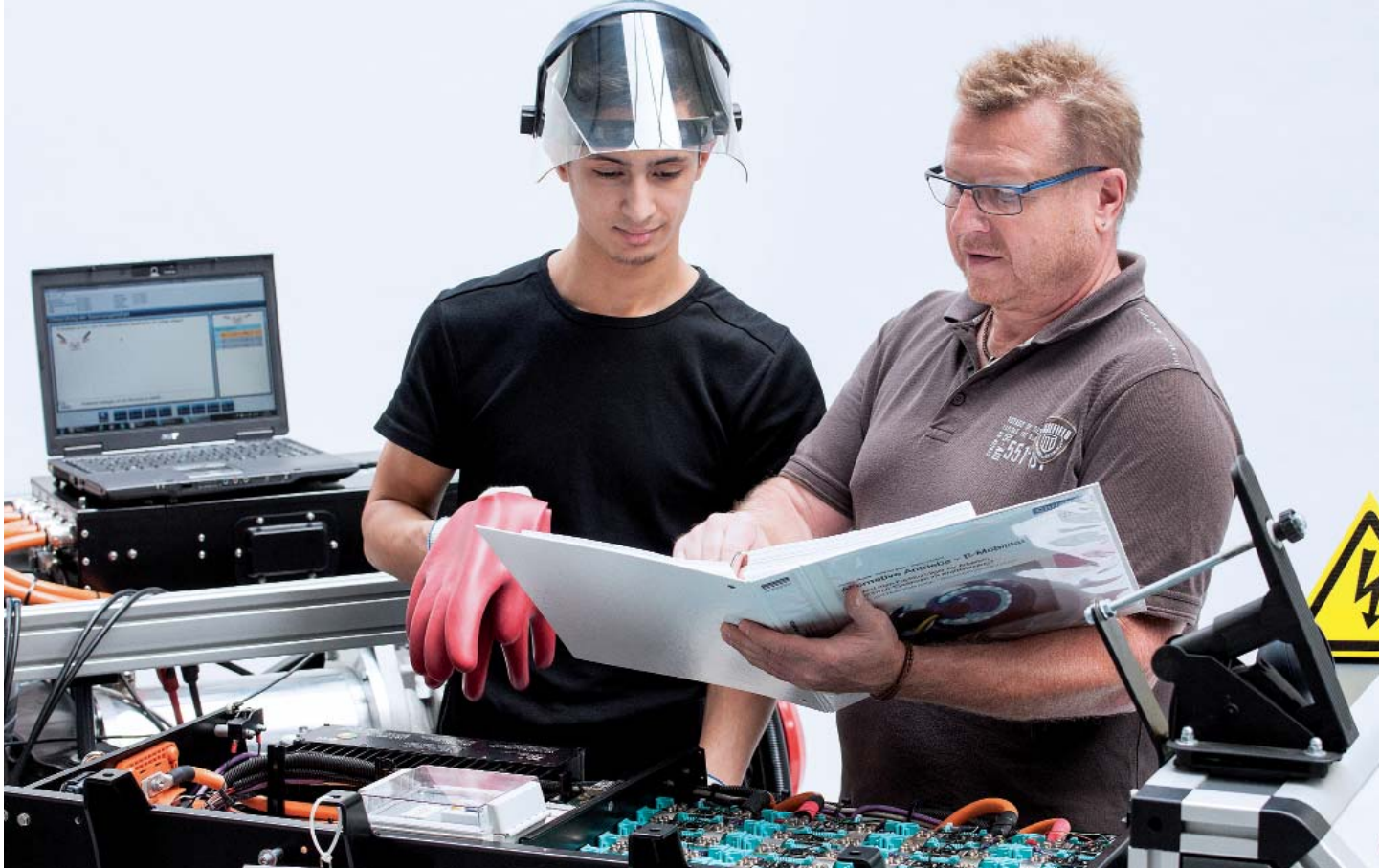

Christiani – Since 85 Years Your Partner for Technical Education

The brand Christiani has more than 85 years of expertise and quality in technical vocational education and training. From correspondence school of early days Christiani has evolved into one of the leading training providers for the entire technical education - from the general education about the technical and vocational training up to further training.

■ With passion for your wishes

With Christiani teaching materials already hundreds of thousands of people have successfully launched their careers, have continuously deepened their knowledge or have new skills acquired. Our employees will assist you in selecting the appropriate materials.

■ Hands on

We know what it takes. We develop many of our teaching concepts in collaboration with leading industry partners - always with the focus on current and future requirements in the labor market.

■ Our motivation

Customer satisfaction is the most important measure of the quality of our products and services. We are committed to continue to be the premier source for technical training for our customers.



Competence – from planning up to implementation
 Theory and practice in one single room
 Modern training systems and didactical variety
 Motivation and sustainable learning success

Christiani training lab concepts: We accompany you step by step

Whether you want to extend your existing specialised training lab or set up a new one – Christiani is your partner for designing and setting up workshops and laboratories for advanced technical education and technical training. Using our knowledge and expertise as well as our network, we will find the solution to your needs.

■ Our modules at a glance:



1. Requirements Analysis



2. Planning



3. Design



4. Implementation



5. Train-the-Trainer



6. Learning Outcome Test



360° View: Our training labs are now also available online

Visit www.christiani-training-lab.com to „take a stroll“ around our 3D, virtual specialised training labs. You will also find detailed information about each of the showrooms and the learning objectives to be accomplished there.



www.christiani-training-lab.com

Experience the Christiani technical training labs in 3D and 360° all-round view.

Technical Training in:

- Mechanics
- Automation Technology
- Electronics
- Renewable Energy
- Sanitation /HVAC
- Automotive Technology





Christiani projects international

BRAZIL

Christiani equipped the State University in Rio de Janeiro with a mechatronic system, incl. training for professors.

CHINA

Training stands for the training in the field of automotive technology, incl. train-the-trainer.

ETHIOPIA

In 2015 in Ethiopia, six automotive training centres are being equipped. Christiani is substantially involved in this project by supplying numerous high-quality training stands.

INDIA

Joint venture CSTT: Together with Sharpline, Christiani maintains a training centre in Mumbai, training courses are conducted mainly in the fields of CNC, PLC and mechatronics.

IRAQ

Christiani supplied training stands for the automotive sector to the University of Salahaddin in Erbil, northern Iraq. In addition to this, train-the-trainer courses.

LEBANON

Successful setup of an examination system in cooperation with the MEHE (Ministry of Education and higher Education).

LUXEMBOURG

Creation of a mechatronics training concept for the Luxembourg Ministry of Education.

MALAYSIA

Mechatronics teaching systems for five polytechnical colleges, incl. train-the-trainer.

MEXICO

Equipping a training centre in Mérida with automotive mechatronics equipment, incl. train-the-trainer.

MONGOLIA

Christiani is a partner in a GIZ project in Mongolia, which involves a 3-year training project in the industrial mechanics, electrotechnical and construction sectors.

MOROCCO

In 2014 in Morocco, Christiani contributed to equipping of a renewable energies training centre by supplying training stands.

PERU

Establishment of an automotive training centre at the technical educational institute TECSUP, incl. train-the-trainer.

ROMANIA

Seminars for teachers and trainers in mechatronics about the basics of the action-oriented training, incl. didactical documents and teaching systems.

RWANDA

„Energy Explorers“ campagne for renewable energy with Christiani products.

SWITZERLAND

Equipment of four solateur schools (solarthermic profession) with teaching systems for the sector renewable energy.

TUNISIA

Equipping training centres in Kebili and Ariana, with training stands for the automotive and renewable energy sectors.



Our international team is pleased to advice you

INTERNATIONAL NETWORKS & INSTITUTIONS

CONTACT

Markus Milwa
International Affairs
Mobile: + 49 151 261 084 88
Fax: + 49 7531 5801-85
milwa@christiani.de
www.christiani-international.com



ASIA-PACIFIC

CONTACT

Lisa Kuner
Team Leader Export
Phone: + 49 7531 5801-54
Fax: + 49 7531 5801-85
kuner@christiani.de
www.christiani-international.com



NORTH AMERICA, MEXICO

CONTACT

Ferdinand Ganser
Export Manager
Mobile: + 49 151 186 177 16
Fax: + 49 7531 5801-85
ganser@christiani.de
www.christiani-international.com



NEAR-MIDDLE EAST/NORTH AFRICA

CONTACT

Fathi Jamal
Export Manager
Mobile: + 49 151 121 251 47
Fax: + 49 7531 5801-85
jamal@christiani.de
www.christiani-me.com



LATIN AMERICA, SPAIN, PORTUGAL

CONTACT

Maiken Kayser
Export Manager
Phone: + 49 7531 5801-945
Fax: + 49 7531 5801-85
kayser@christiani.de
www.christiani.es



AFRICA, RUSSIA, CENTRAL ASIA

CONTACT

Nadja Parcsami
Export Manager
Phone: + 49 7531 5801-38
Fax: + 49 7531 5801-85
parcsami@christiani.de
www.christiani-international.com



EUROPE

CONTACT

Sandra Strobel
Export Manager
Phone: + 49 7531 5801-9904
Fax: + 49 7531 5801-85
strobel@christiani.de
www.christiani.eu



TVET discussion platform

- join our group now on **LinkedIn**



Get connected and join our group!
Exchange your worldwide experiences and opinions about technical and vocational education and training on the Christiani TVET discussion platform on LinkedIn!



christiani-tvet.com

Entering the world of technical training: by clicking on the desired region you will be re-directed to the website or contact of your national representative.

Training in automotive technology

Suspension and brakes



Automotive electrics



Engine technology



Alternative drive systems and high-voltage technology



Experience the Christiani technical training
labs in 3D and 360° all-round view
www.christiani-training-lab.com

Imparting skills to control and regulation systems of drive technology

This technical training lab can be used for training in both vehicle servicing and maintenance as well as engine management diagnostics. As well as learning how modern petrol and diesel engine management systems work, knowledge can be imparted on how sensors and actuators work, how the IPO model (input-process-output) works, how signals are picked up and evaluated and also transferred via data bus, and how to use the latest diagnostic and measuring systems.



The Christiani technical training lab for engine technology offers you the following:

- Theory and practice from a single source
- Motivation to learn and sustainable learning success
- Didactic diversity and practically oriented training media
- Strong partnerships with industry
- Professional consulting – from the planning stage, all the way up to implementation



Experience the Christiani technical training labs in 3D and 360° all-round view
www.christiani-training-lab.com



COMPACT INFO

Technical Training Lab for Engine Technology

Example configuration for 16 workplaces

- Petrol/diesel engine functional models
- Diagnostics stations
- Sensors/actuators in engine management training stand/functional model
- FSI direct petrol injection training stand/functional model
- Common-rail direct diesel injection training stand/functional model
- Training vehicles set up for teaching purposes, including a „fault circuit“ and breakout boxes
- Lifting platforms, workbenches and tool trolleys

Suitable for:

- Automotive professions

Topics/Learning objectives

- Using manufacturer-specific repair manuals and circuit diagrams
- Identifying assemblies in vehicles
- Diagnostics and troubleshooting on petrol and diesel engines
- Function testing on the engine management system
- Petrol and diesel engine exhaust gas after-treatment systems
- Testing sensors and actuators
- Measuring and evaluating signals
- Testing data exchange and data transfer
- Adjusting control units and calibrating systems
- Troubleshooting using the diagnostic interface
- Reading from and clearing the fault code memory

Training on fully functional engines

The training stand facilitates practical training on fully functional original engines from Volkswagen's current range of vehicles. It comes as standard with two original VW test boxes with 105 PIN and 2 mm measuring sockets, the accompanying control equipment adapter, as well as one fault circuit box with 20 practical faults.

VW 1.4 TSI and 1.6 TDI

This makes it possible to present, localise and eliminate realistic malfunctions and faults. A component simulator can be used to manipulate the signals of various sensors as a way of generating defective operating statuses and demonstrating emergency running properties. The original circuit diagrams, repair guides and installation instructions, containing all necessary data, are supplied with each engine. All maintenance, service and repair work that needs to be performed in the real world can therefore be practically demonstrated. All programming and diagnostic work can be performed

using a standard workshop diagnostic device (OBD 2-compatible). A multimeter and/or an oscilloscope are required for the measurement exercises. The apparatus includes a hinged storage fought for measurement or diagnostic devices, an OBD connection and an emergency-off switch.

Since a combustion engine is NOT emissions-free, it may only be used outdoors or in areas that offer the necessary extraction to comply with legal stipulations.



Standard series equipment:

- Fully functional and ready-to-use working engine
- Two original VW test boxes with control equipment adapter
- Twenty-fold fault circuit
- Five-fold component simulator
- Operating manual
- Technical documentation and circuit diagrams

Learning objectives:

- Working with maintenance schedules, wiring diagrams, symbols, terminal designations, wires and wiring connections
- Naming mechanical, electrical and electronic components, assembly groups and systems
- Checking and repairing mechanical, electrical and electronic circuits and systems
- Selecting and using mechanical and electrical measuring and testing equipment
- Measuring and evaluating electrical variables and signals
- Documenting work results and evaluating by comparing with calculated variables and manufacturer specifications
- Making use of the possibilities offered by commonly used workshop diagnosis testers

Scope of delivery:

Ready-to-use and movable functioning engine, including fault circuit, component simulator, break-out boxes for engine management system, circuit diagrams and operating instructions

VW 1.4 TSI and 1.6 TDI

Specifications TSI:

Engine classification code	CAVD
Design	Inline 4-cylinder engine
Displacement	1.390 cm ³
Bore	76,5 mm
Stroke	75,6 mm
Valves per cylinder	4
Compression ratio	10:1
Max. output	118 kW at 5900 rpm
Max. torque	240 Nm at 1500 and 4500 rpm
Engine management system	Bosch Motronic MED 17.5.5
Fuel	Super unleaded with 95 RON
Exhaust gas after-treatment	Three-way catalytic converter, One wide-band Lambda oxygen sensor upstream and one discrete-level oxygen sensor downstream of the catalytic converter
Emissions standard	EU5
Dimensions: L x W x H	1500 x 600 x 1960 mm
Weight:	approximately 300 Kg

Technical features:

- Homogenous operation (oxygen sensor 1)
- Layer high-pressure start
- Exhaust gas turbocharger with waste gate
- Switchable mechanical supercharger boosting
- Air/charge air cooling
- Two-circuit cooling system
- Regulated duo-centric oil pump
- Requirement-regulated fuel system
- High-pressure electric fuel pump with integrated pressure limiting valve

Specifications TDI-CR:

Engine classification code	CAYC
Design	Inline 4-cylinder engine
Displacement	1598 cm ³
Bore	79,5 mm
Stroke	80,5 mm
Valves per cylinder	4
Compression ratio	16,5:1
Max. output	77 kW at 4400 rpm
Max. torque	250 Nm at 1500 and 2500 rpm
Engine management system	Simos PCR 2.1
Fuel	Diesel as per DIN EN590
Exhaust gas after-treatment	Exhaust gas recirculation, oxidation catalytic converter and diesel particulate filter
Emissions standard	EU5
Dimensions: L x W x H	1500 x 600 x 1960 mm
Weight:	approximately 300 Kg

Technical features:

- Continental PCR 2 common-rail injection system with piezo injection valves
- Exhaust gas recirculation module with exhaust-gas recirculation valve and cooler for exhaust gas recirculation
- Plastic intake manifold without swirl valve adjustment
- Spur gear drive of the camshafts without backlash compensation
- High-pressure pump with gearwheel pre-supply pump
- Electric fuel pump for pre-supply in the fuel tank

Article	Order.-No.
Training Stand/Functioning Engine: VW 1.4 TSI with Supercharger and Turbocharger	82-82745

Article	Order.-No.
Training Stand/Functioning Engine: VW 1.6 TDI with 4-Valve Technology	82-82746

Recommended Accessories (optional)



Digital storage oscilloscope

This combination of one digital Two-channel /20 MHz storage oscilloscope and one true RMS multimeter represents the ideal solution for any measurement task. The creative shortcut design simplifies operation, the high-resolution 3.8" TFT colour display (640 x 480 pixels - 65,535 colours) makes it easy to observe the curves, while the long service life of the lithium-ion battery guarantees continuous operation. The device is therefore ideal for use in modern testing/ measurement environments and for taking on-site measurements.

Order-No.
82-58053



VCDS pro basic kit

The VCDS pro basic kit with HEX+CANUSB interface hardware is suitable for all VAG models with diagnostic capability from 1992 to the current model year. Additional adapters are available as an option for individual and older models and third-party brands in particular (e.g. Linde, KTM). In the EOBD mode, this interface also enables inter-brand exhaust-relevant diagnostic functions (e.g. for Mercedes Benz, BMW, newer Opel, all French brands, many Asian brands and many more).

Order-No.
82-82251

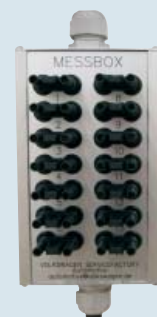

VW adapter engine compartment test box

Basic Golf 6 platform

Used as a junction/test box between the engine cable harness and bodywork cable harness.14-pin. Can also be used on the training vehicle, engine training stand, functional model and SSC functional model.

Order-No.
82-92970

Engine Technology

Training Stand/Functioning Engine

Petrol/Direct Injection – VW Golf 1.4 FSI

The FSI petrol direct injection training stand has been created using original components from the Golf 1.4 FSI. During its design, particular emphasis was placed on ensuring that the components and their connections are established as realistically as possible. This allows measurements to be taken in real-world conditions for component and system diagnostics.

Various training situations can be simulated using the integrated fault circuit. A component simulation allows various load conditions to be shown. The key advantage of the FSI functional model is its ability to demonstrate the functions and procedures of direct petrol injection under real conditions in the classroom, yet without any emissions.

All original components of the FSI direct petrol injection system with demand-regulated high-pressure pump and the fuel system are both fully functional and suitable for diagnostic purposes. The signals and values can be measured directly on the components or exported via the OBD connection for use with standard commercial diagnostic systems.

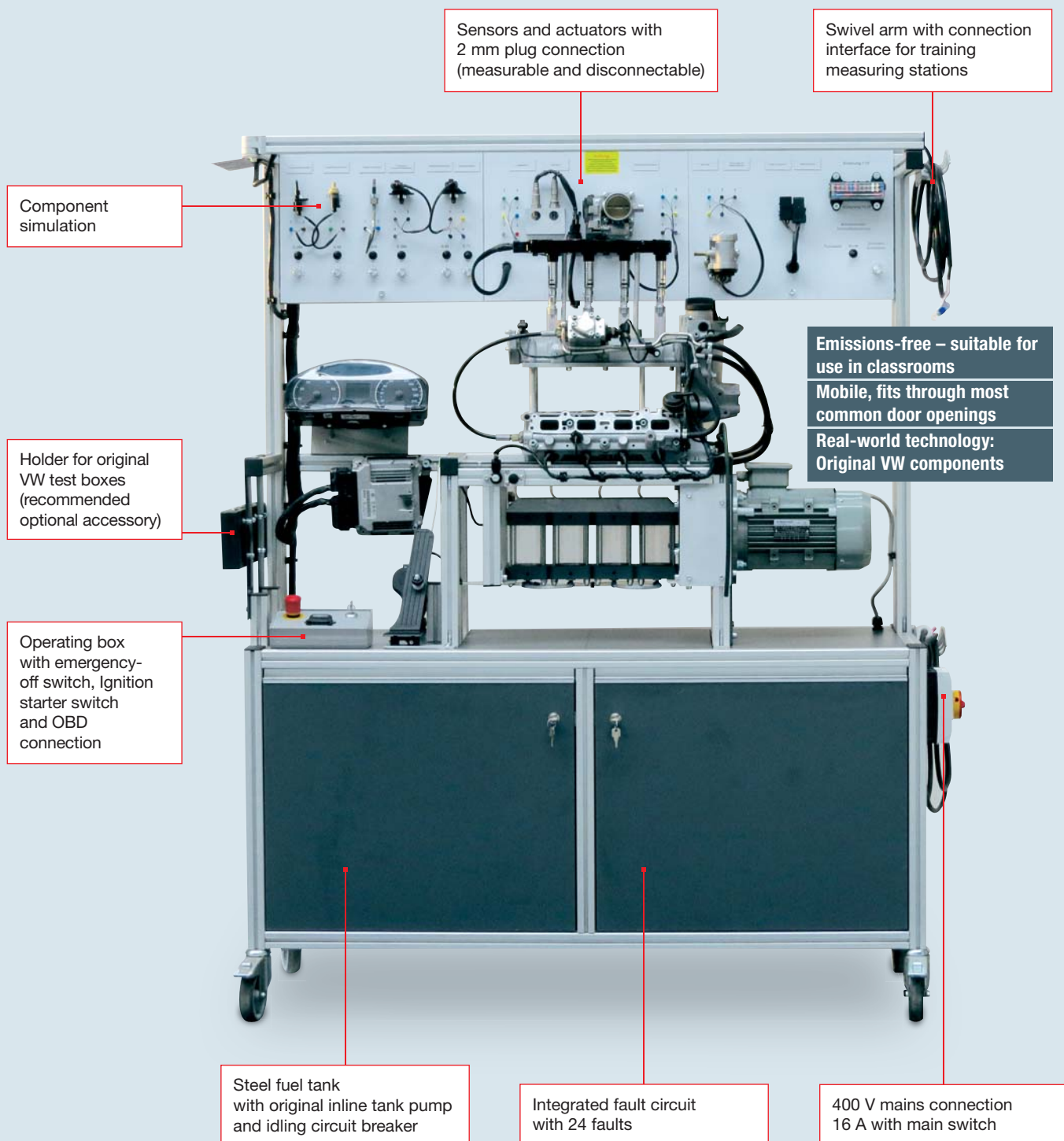

Petrol/Direct Injection – VW Golf 1.4 FSI

Standard series equipment:

- Bosch Motronic MED 9.5.10 FSI system
- Operating box with ignition starter switch, emergency-off switch and OBD connection
- Interface for training measuring station
- Fuel tank with original inline tank pump and fuel pump control unit
- Fuel level indicator via instrument cluster
- Fuel cooler for the original Bosch test oil system
- Idling shutdown for the closed system in the event of any leaks
- Isolation of travel encoder with manual speed adjustment for load simulations

Learning objectives:

- Working with wiring diagrams, symbols, terminal designations, wires and wiring connections
- Naming mechanical, electrical and electronic components, assembly groups and systems
- Documenting, analysing and evaluating measured values, signals and error protocols
- Making use of the possibilities offered by commonly used workshop diagnostic devices
- Selecting and using mechanical and electrical measuring and testing equipment

Scope of delivery:

Ready-to-use and movable functional model, including fault circuit, circuit diagrams, operating manual and voltage-stabilised 12 V switched mode power supply

Specifications:

Mains connection: 400 V 16 A
Dimensions: W x D x H 1500 x 600 x 1960 mm
Weight: approx. 240 kg

Article	Order-No.
Training Stand/Functional Model VW FSI	82-77189

Recommended Accessories (optional)



VW test box, 105-pin, VAG

Order-No.
82-86594



Adapter cable set, 154-pin, VAG

Order-No.
82-86595



Trainee measuring station

The student measuring station for Christiani training stands is a line of general purpose, robust plastic case with carrying handle. The case is equipped with 45-point sockets with 2mm diameter. The measuring system can be used on all Christiani training stands that have the corresponding interface. Each test site includes an expansion via plug-in connection to up to a total of 14 units. A connecting cable for connection and / or extension is supplied with each measuring station.

Order-No.
82-83454

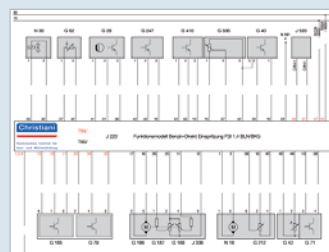

Circuit diagram pad VW 1.4 FSI petrol engine code BKG

The diagram switching signs and symbols were created according to original circuit diagram of the training stand. It contains exemplary excerpts from the overall system. The inputs and outputs of the components which need to be tested are labeled with the pin assignment according to original plan.

Order-No.
82-95107

Engine Technology

Training Stand/Functioning Engine

Common-Rail Injection System with Piezo Injection Valves – VW Golf 2.0 TDI

The training stand with common-rail injection system and piezo injection valves has been created using original components from the Golf 2.0 TDI. During its design, particular emphasis was placed on ensuring that the components and their connections are established as realistically as possible. This allows measurements to be taken in real-world conditions for component and system diagnostics.

Various training situations can be simulated using the integrated fault circuit. A component simulation allows various load conditions to be shown. The key advantage of the CR functional model is its ability to demonstrate the functions and procedures of the high pressure common-rail injection system for diesel engines under real conditions in the classroom, yet without any emissions.

All original components of the common-rail injection system and the fuel delivery system, including the fuel pump for pre-feed and additional fuel pump, have been set up in such a way that they are fully functional and suitable for diagnostic purposes. The signals and values can be measured directly on the components or exported via the OBD connection for use with standard commercial diagnostic systems.

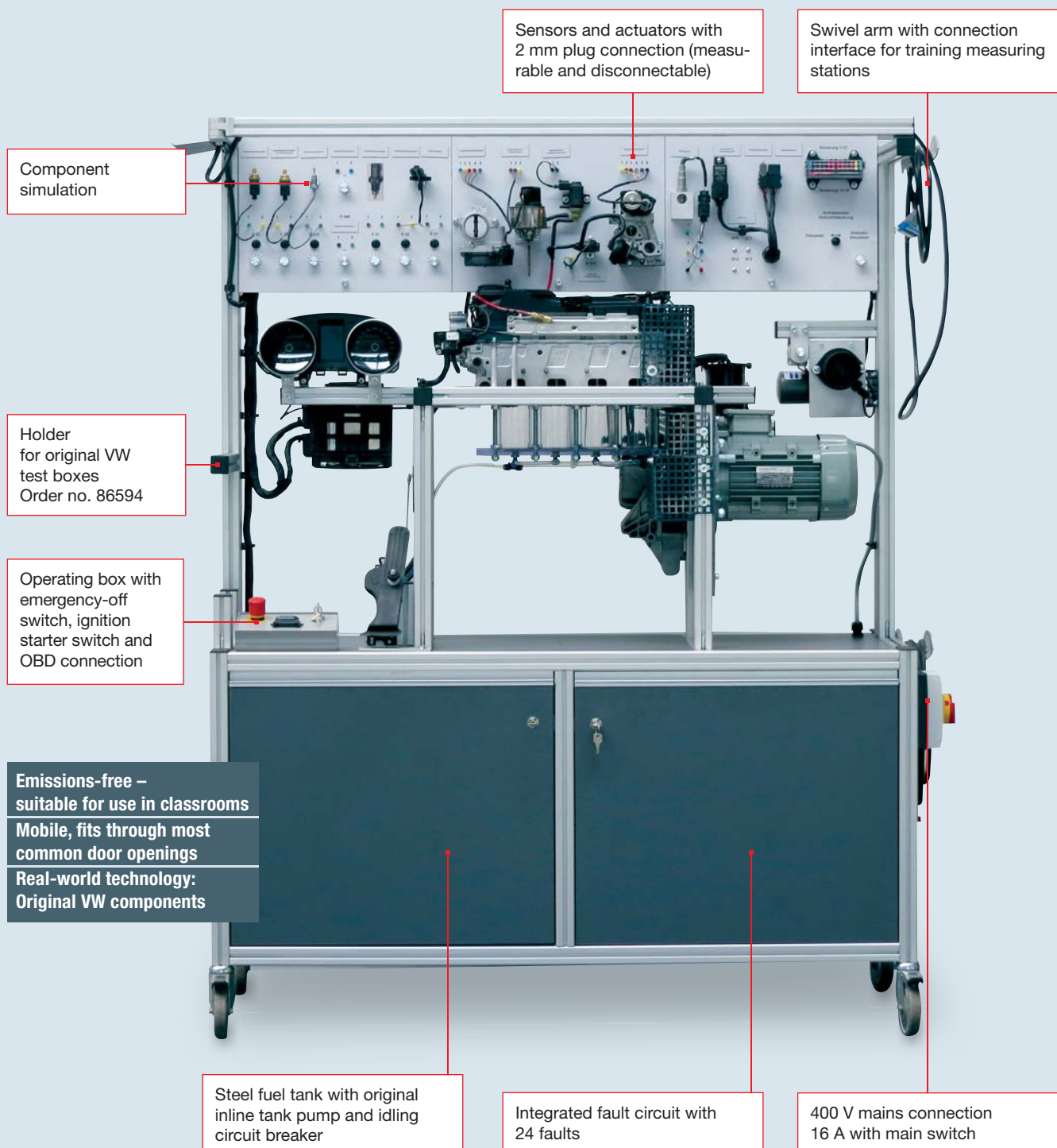

Common-Rail Injection System with Piezo Injection Valves – VW Golf 2.0 TDI

Standard series equipment:

- Bosch EDC 17 common-rail injection system
- Operating box with ignition starter switch, emergency-off switch and OBD connection
- Interface for training measuring station
- Fuel tank with original inline tank pump and additional fuel pump
- Fuel level indicator via instrument cluster
- Fuel cooler for the original Bosch test oil system
- Idling shutdown for the closed system in the event of any leaks
- Isolation of travel encoder with manual speed adjustment for load simulations
- Manually controllable air mass for changing the air-to-fuel ratio

Learning objectives:

- Working with wiring diagrams, symbols, terminal designations, wires and wiring connections
- Naming mechanical, electrical and electronic components, assembly groups and systems
- Documenting, analysing and evaluating measured values, signals and error protocols
- Making use of the possibilities offered by commonly used workshop diagnostic devices
- Selecting and using mechanical and electrical measuring and testing equipment

Scope of delivery:

Ready-to-use and movable functional model, including fault circuit, circuit diagrams, operating manual and voltage-stabilised 12 V switched mode power supply

Specifications:

Mains connection: 400 V 16 A
Dimensions: W x D x H 1500 x 600 x 1960 mm
Weight: approx. 280 kg

Article

Order-No.

Training Stand - Training course common-rail with Piezo injectors

82-77188

Recommended Accessories (optional)



VW test box, 105-pin, VAG

Order-No.

82-86594



Adapter cable set, 154-pin, VAG

Order-No.

82-86595



Trainee measuring station

The student measuring station for Christiani training stands is a line of general purpose, robust plastic case with carrying handle. The case is equipped with 45-point sockets with 2mm diameter. The measuring system can be used on all Christiani training stands that have the corresponding interface. Each test site includes an expansion via plug-in connection to up to a total of 14 units. A connecting cable for connection and / or extension is supplied with each measuring station.

Order-No.

82-83454

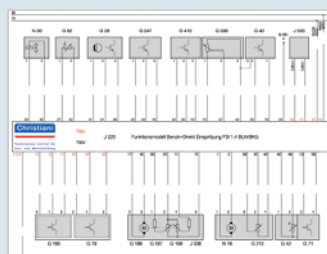

Circuit diagram pad VW Common-Rail

The diagram switching signs and symbols were created according to the original circuit diagram of the training stand. It contains exemplary excerpts from the overall system. The inputs and outputs of the components which need to be tested are labeled with the pin assignment according to original plan.

Order-No.

82-95107

Training on original engines from Opel, Ford, Mercedes or VW!

You can choose from a multitude of training stands with engines from Opel, Ford, Mercedes or VW. The Christiani functioning engines are fitted to a movable frame made of high-strength aluminium profile. The instrument cluster, fuse block, as well as the ignition switch, emergency-off switch and a component simulation are fitted to the front panel of the control console.

Passenger Vehicle Functioning Engines

The component simulation is used to display various operating states and emergency running properties. Manipulating individual sensors allows trainees to visually follow the reaction of the engine management system, for example by evaluating measured value blocks or fault code entries. The original OBD interface and the interface for training measuring stations are both located on the lower front panel. This makes it possible to connect standard workshop diagnostics systems and training measuring stations (up to 14 units in series). A pull-out storage tray for measuring equipment, laptop or work documentation can be found below the interface plate.

The fitted and lockable fault circuit allows 24 different electrical faults to be connected within the engine management system, the power supply system, the fuel injection system and the fuel supply system. The malfunctions that result from this enable the trainer to use the various realistic training situations.

Training measuring stations or test boxes with test adapter for the engine management system are optionally available for troubleshooting. These allow the signals and voltage values of all

system-relevant components to be measured/diagnosed. In addition to this, parallel measuring adapters can be fitted to the plug connections of the components to which faults are applied. This makes it possible to measure the electrical line connections, including those in hard-to-reach places, without having to dismantle the equipment. The training stand has a restbus simulation for generating the necessary signals of drive components which are not fitted. This guarantees full and unrestricted functionality and diagnostic capabilities.

Rotating components and assemblies at high operating temperatures are protected from unintentional physical contact. All components used for genuine functions are original components from the respective manufacturer.

The set-ups shown are examples of functioning engine training stands there have been assembled in the past.

Since a combustion engine is NOT emissions-free, it may only be used outdoors or in areas that offer the necessary extraction to comply with legal stipulations.

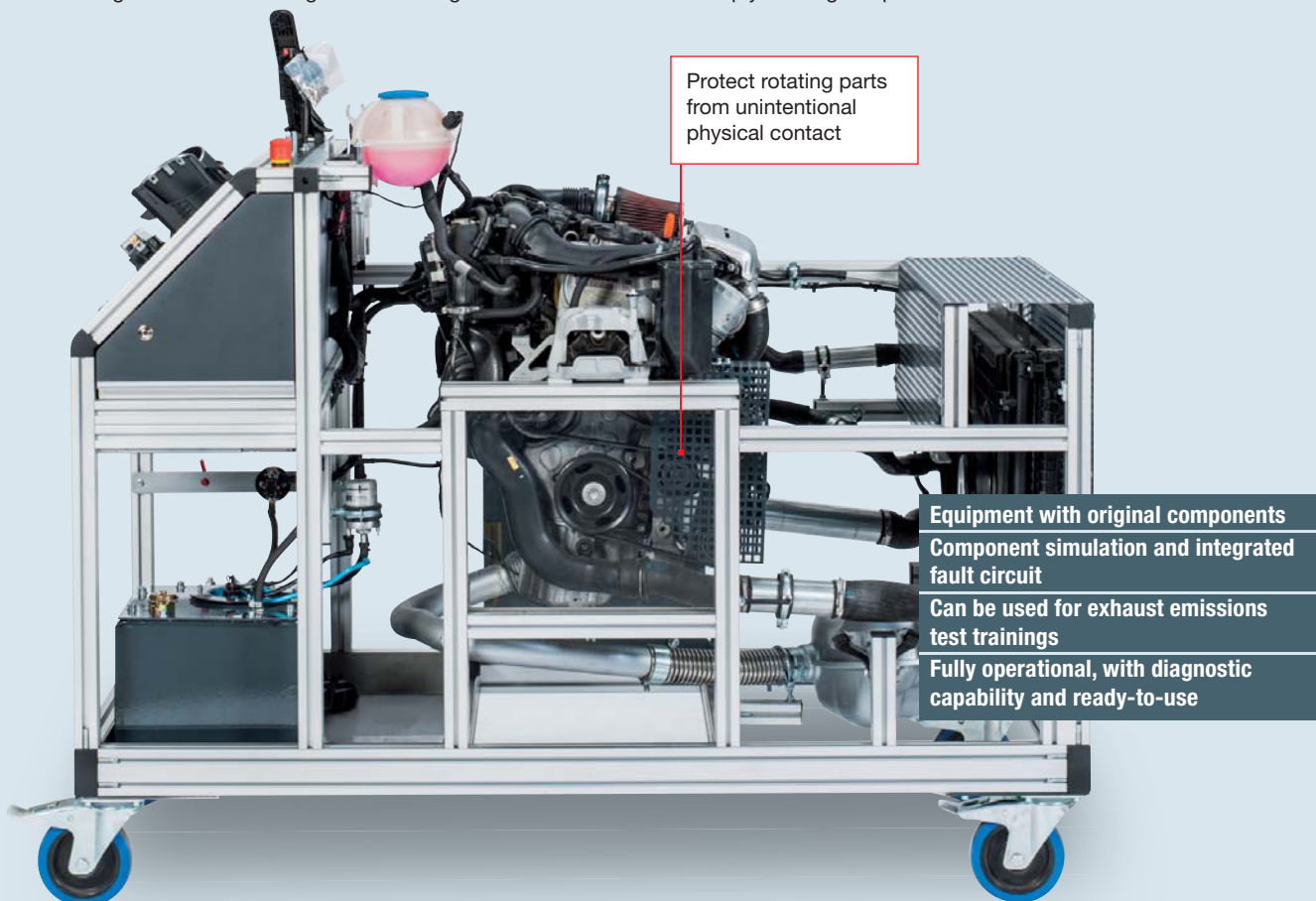

Passenger Vehicle Functioning Engines



Standard series equipment:

- Control panel with instrument cluster, ignition starter switch, emergency-off switch and OBD connection
- Lockable component state simulation for manipulating various sensor values and presenting emergency running properties
- Interface for training measuring station
- Fuel tank made of sheet steel (20 litre capacity) with original inline tank pump, fuel pump control unit and closed original tank ventilation system
- Fuel level indicator via instrument cluster
- Battery main switch

Possible uses:

- Checking and repairing mechanical, electrical and electronic circuits and systems
- Assembly and disassembly work on the engine, working with maintenance and circuit diagrams
- Measuring electrical variables and signals, as well as their documentation and evaluation
- Identifying individual components and learning about their operating characteristics and parameters
- Learning how to use standard workshop diagnostic equipment
- Working with electrical and mechanical measurement and test equipment, such as return flow volume measurement
- Checking components to decide which repair measures are necessary (if any)

Learning objectives:

- Working with maintenance schedules, wiring diagrams, symbols, terminal designations, wires and wiring connections
- Naming mechanical, electrical and electronic components, assembly groups and systems
- Checking and repairing mechanical, electrical and electronic circuits and systems
- Selecting and using mechanical and electrical measuring and testing equipment
- Measuring and evaluating electrical variables and signals
- Documenting work results and evaluating by comparing them with calculated variables and manufacturer specifications
- Making use of the possibilities offered by commonly used workshop diagnostic devices
- Making use of problem resolution strategies and/or alternatives during diagnosis
- Documenting, analysing and evaluating measured values, signals and error protocols
- Examining individual components and making a decision about necessary repair measures

Scope of delivery:

Ready-to-use and movable functional model, including fault circuit, datasheets, circuit diagrams and operating instructions

Specifications:

Dimensions: L x W x H 1700 x 850 x 1600 mm

Weight: approximately 200 - 380 Kg, depending on the model

▶ You can find further information on the following pages – please turn over.

Engine Technology

Training Stand/Functioning Engine

Passenger Vehicle Functioning Engines

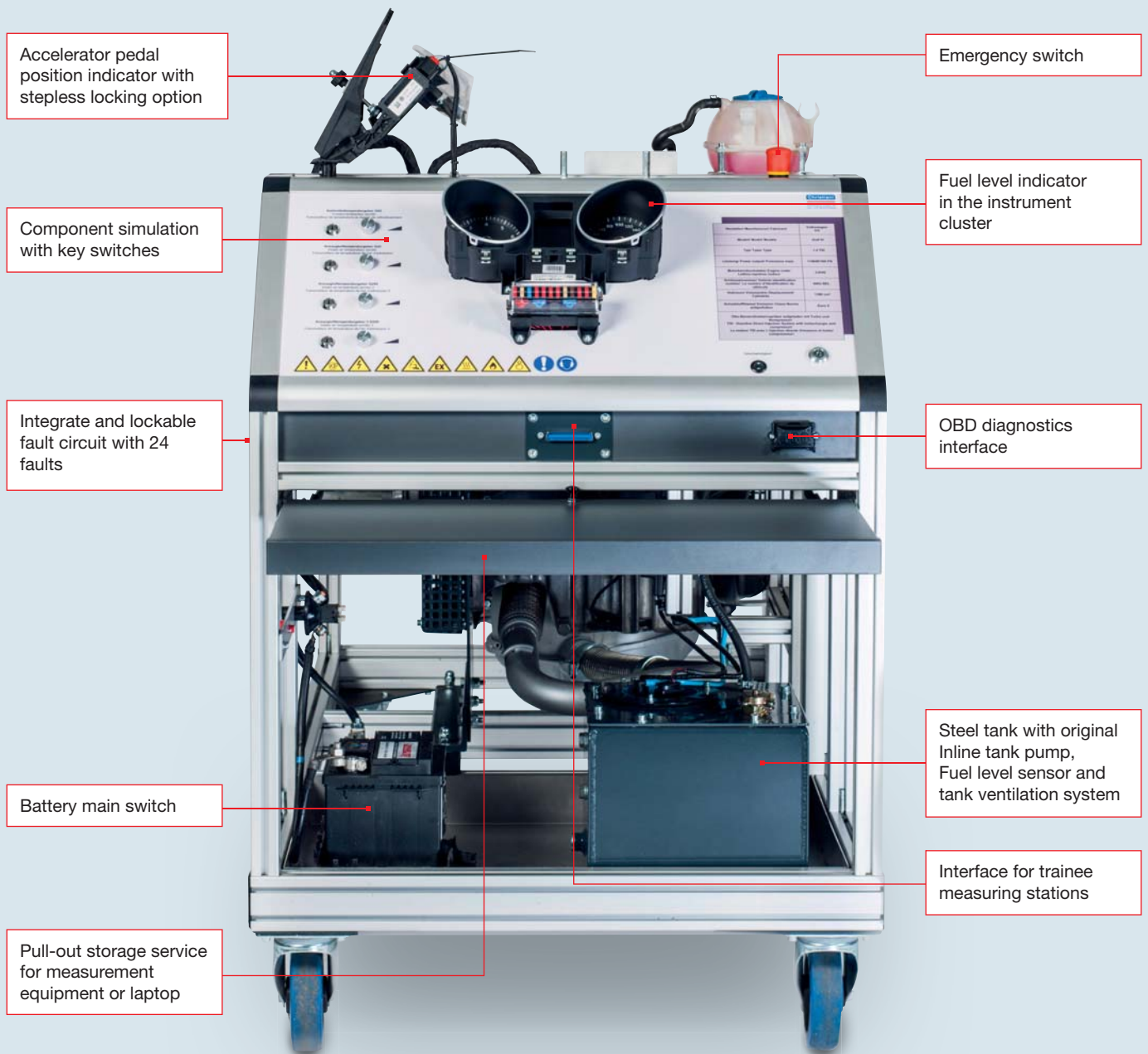

Petrol engines that can be supplied (export version)	Order-No.
Opel Multipoint	82-84240
VW 1.4 MPI	82-84482
VW 1.4 TSI CAXA	82-83888
VW 1.4 TSI CAVD	82-93069
VW 1.4 FSI	82-77201
VW 2.0 TFSI	82-83283
VW 2.0 TFSI with LPG	82-84067
VW 1.2 TSI	82-86551
VW 1.6 Bi-Fuel with LPG	82-88867

Diesel engines that can be supplied (export version)	Order-No.
Mercedes 200/220 CDI	82-77181
Ford 1.4 TDCI	82-84242
Opel 1.3 CDTI	82-84241
VW 1.6 TDI-CR	82-83749
VW 1.9 TDI-PD	82-83172
VW 2.0 TDI-CR	82-84490
VW 2.0 TDI Blue Motion	82-88753
VW Crafter 2.0	82-89253
VW 1.2 TDI-CR 3-Cylinder	82-92499

Recommended Accessories (optional)

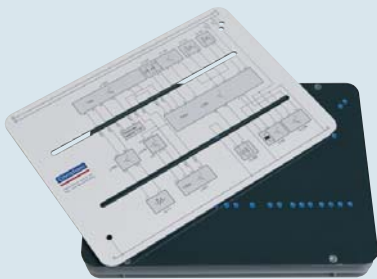

Measuring station

The measuring station for Christiani training stands is a universally deployable and robust plastic case with carrying handle. The case comes with 45 safety measuring sockets with a diameter of 2 mm. The measuring station can be used with all Christiani training stands that have a measuring station interface. Each measuring station can also be expanded up to 12 units via the plug connection. One connection cable is supplied per measuring station for connection and/or extension purposes. The suitable circuit diagram for the training engine has to be ordered separately.

Order-No.

82-83454



VW test box, 105-pin, VAG 1598/42

In connection with original VW adapter cable sets, the test box allows measurements to be taken with the multimeter and/or oscilloscope on components and line connections. It is fully screened against radiated interference and equipped with an additional earth connection.

Order-No.

82-86594



VW Adapter cable set, 154-pin VAG 1598/39

The adapter cable is required in connection with the new test box, VAG 1598/42, for checking the engine control unit. The new test box, VAG 1598/42, is not included in the scope of supply. Two test boxes (order no. 86594) are required for taking measurements. The measurements are performed in parallel. The adapters also have additional connections.

Order-No.

82-86595



Installation frame

with angle bracket and accessories
System frame made of extruded aluminium profile, including powder coated mounting brackets for the measurement boxes and accessories for attachment to the system frame of Christiani Training Stand/Functioning Engines: (only for engines from Volkswagen).

Order-No.

82-13538



Digital storage oscilloscope

This combination of one digital 2-channel/20 MHz storage oscilloscope and one true RMS multimeter represents the solution for any measurement task. The creative shortcut design simplifies operation, the high-resolution 3.8" TFT colour display (640 x 480 pixels - 65,535 colours) makes it easy to observe the curves, while the long service life of the lithium-ion battery guarantees continuous operation.

Order-No.

82-58053



Measurement cable kit

Measurement cable kit for use with the oscilloscope, order no. 58053. For measuring signals and values on engine training stands with and without test box, as well as on CAN-bus training systems with measuring tips, laboratory cables and adapters with 4 mm measuring sockets.

Order-No.

82-80968



Return volume measuring system

Lehnert Tools Common-Rail diagnostic system with recirculation process for measuring the return flow volume, pressure and temperature (four cylinders). Only suitable for use with diesel engines.

Order-No.

82-86604

Engine Technology

Training Stand/Functioning Engine

Sensors/Actuators

The training stand consists of a networked system of engine management system, instrument cluster and brake control unit on the basis of the Golf 6 1.4 with the engine identification CGGA. The objective of this training stand is to target training of the IPO principle (Input-Processing-Output) and provide visible examples of this. The components fitted are colour coded based on their respective task. The front panel is also laminated with a printed film and can be written on using water-soluble pens.

All components are connected and labelled as per the original Volkswagen circuit diagram. The connection has been implemented using plug connections with measuring sockets. These allow the signals to be measured, recorded or visualised using a multimeter or oscilloscope. All measured values are also to be exported to the measured value blocks via the OBD interface using a suitable diagnostics system.

The rotary speed of the camshaft, as well as speed control for the pole wheel for the speed sensors are controlled using a potentiometer. Both forward and reverse travel can be simulated on the wheel speed sensors. For this purpose, an additional wheel speed sensor with reversing detection is also provided.

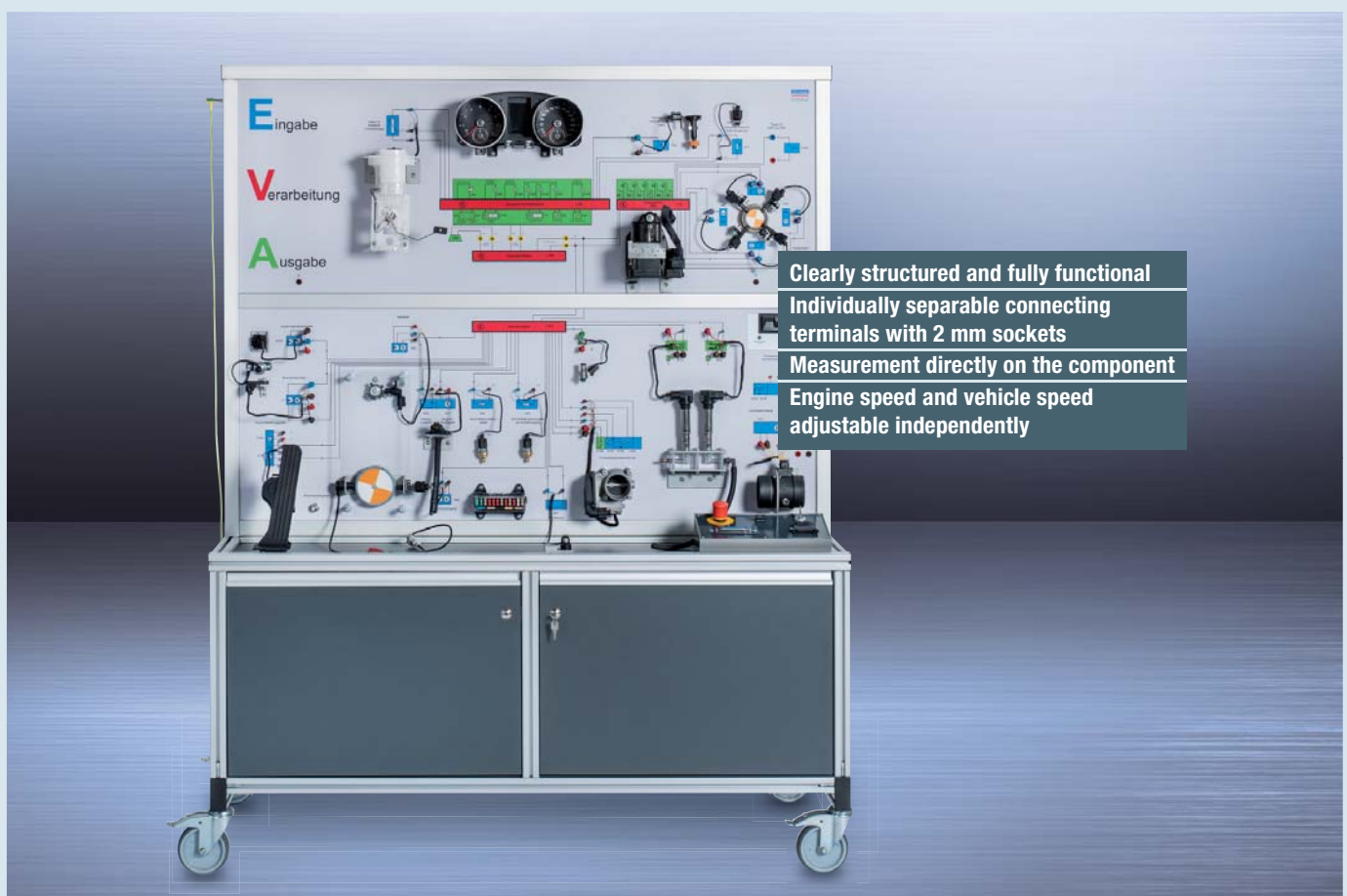

Clearly structured and fully functional
Individually separable connecting terminals with 2 mm sockets
Measurement directly on the component
Engine speed and vehicle speed adjustable independently

The following are digitally printed on the front panel with circuit diagram:

Sensors:

- Hall sensor, inductive sensor, reed contact, knock sensor, NTC and PTC sensor, TPMS sensor, photosensors, pressure sensors, position indicators, angle sensors, hot-film mass airflow sensors, active wheel speed sensors and an additional sensor with reversing detection

Actuators:

- Ignition coils with power output stages, spark plugs in the Makrolon block and connection valves for underpressure and overpressure, electromotive throttle controller, transducer, injection valve, brake control unit, instrument cluster

A digital hot-film mass airflow sensor is also fitted (HFM 6). It serves as supplementary units and is not directly linked to the engine management system assembled. An oscilloscope enables the pulse-width modulation during air flow to be visualised.

The functional model is activated via the operator panel, which includes the ignition starter switch, the interfaces for OBD and trainee measuring stations, as well as an emergency-off switch.

Sensors/Actuators

Standard series equipment:

- Ready-to-use and movable functional model
- Voltage-stabilised switched mode power supply
- Front can be labelled with marker pen
- OBD diagnostics interface
- Interface for trainee measuring stations

Learning objectives:

- Working with maintenance schedules, wiring diagrams, symbols, terminal designations, wires and wiring connections
- Naming electrical and electronic components, functional units and systems
- Selecting and using electrical measuring and testing equipment
- Measuring and evaluating electrical variables and signals
- Documenting work results and evaluating by comparing them with calculated variables and manufacturer specifications
- Documenting, analysing and evaluating measured values, signals and error protocols

Possible uses:

- Working with wiring diagrams, symbols, terminal designations, wires and wiring connections
- Measuring electrical variables and signals, as well as their documentation and evaluation
- Making use of the possibilities offered by standard workshop measurement and diagnostic equipment
- Identifying individual components and learning about their operating characteristics and parameters
- Examining individual components and making a decision about necessary repair measures

Scope of delivery:

Ready-to-use and movable functional model, including voltage-stabilised 12 V switched mode power supply, datasheets, circuit diagrams, manual and operating instructions.

Specifications:

Dimensions: L x W x H 1600 x 800 x 1950 mm
Weight: approx. 160 kg
Electrical connection: 110 V/240 V mains connection

Article

Order-No.

**Functional Model/Training Stand:
Sensors/Actuators**

82-81979

Other version

Functional Model/Training Stand: Sensors/Actuators with Parking Aid (Park Distance Control)

Design same as article no.: 81979, although also with fully functional PDC system fitted to both the left-hand and right-hand side panel of the functional model, each with four front and rear ultrasonic sensors. The connections employ plug-in connectors and measuring sockets. The PDC activation switch is located on the operator panel.

Article

Order-No.

Functional Model/Training Stand: Sensors/Actuators with Parking Aid (Park Distance Control)

82-93025

Recommended Accessories (optional)



Digital storage oscilloscope

This combination of one digital Two-channel/20 MHz storage oscilloscope and one true RMS multimeter represents the ideal solution for any measurement task. The creative shortcut design simplifies operation, the high-resolution 3.8" TFT colour display (640 x 480 pixels - 65,535 colours) makes it easy to observe the curves, while the long service life of the lithiumion battery guarantees continuous operation.

Order-No.

82-58053



Trainee measuring station

The student measuring station for Christiani training stands is a line of general purpose, robust plastic case with carrying handle. The case is equipped with 45-point sockets with 2mm diameter. The measuring system can be used on all Christiani training stands that have the corresponding interface. Each test site includes an expansion via plug-in connection to up to a total of 14 units. A connecting cable for connection and / or extension is supplied with each measuring station.

Order-No.

82-83454

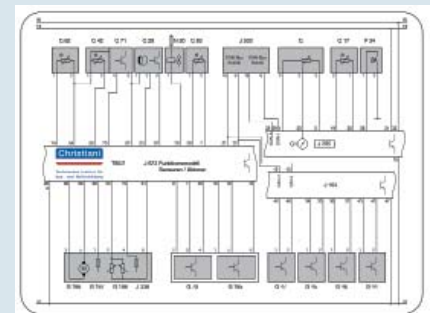

Circuit diagram pad VW Sensors/Actuators

The diagram switching signs and symbols were created according to the original circuit diagram of the training stand. It contains exemplary excerpts from the overall system. The inputs and outputs of the components which need to be tested are labeled with the pin assignment according to the original plan.

Order-No.

82-89767

Engine Technology

Training Stand/Functioning Engine

TSZI, TSZH and Fully Electrical Ignition with Resting High Voltage Distribution

This test stand was created from original components from various vehicles (Volkswagen, Ford, GM). During the design phase, particular emphasis was placed on creating the most realistic representation possible of the components and their connections, so that original documents and wiring diagrams from Volkswagen AG can be used. This makes it possible to perform measurements, fault simulation and diagnostics as on a conventional vehicle. By manipulating the components, various faults have been incorporated into the test set-up so that practical troubleshooting is possible.

Transistorised ignition with Hall sensor, transistorised ignition with inductive sensor and resting high voltage distribution are all available. The connections on each component are designed as forward-facing 4 mm safety sockets.

Each connection is labelled with the terminal designations as per DIN 72522 or, depending on the model in question, with the designations of the respective OEM wiring diagram. So that all measuring points can be worked on using an oscilloscope or a multimeter, these measuring points are fitted to the front panel and therefore easily accessible. The components are connected using 4 mm laboratory safety cables.

There is also an option to connect up to 14 training measuring stations to the experimental apparatus via the interface provided. This allows measurement exercises to be performed using the multimeter and oscilloscope with several trainees at the same time. The base cabinet with lockable folding doors also serves as storage space for the measuring equipment/optional accessories. The movable apparatus comprises a high-strength aluminium profile with four lockable heavy-duty steering rollers. Circuit diagrams and work documents are included in the scope of supply.

Connection options:
Training measuring stations, multimeter, oscilloscope, stroboscope

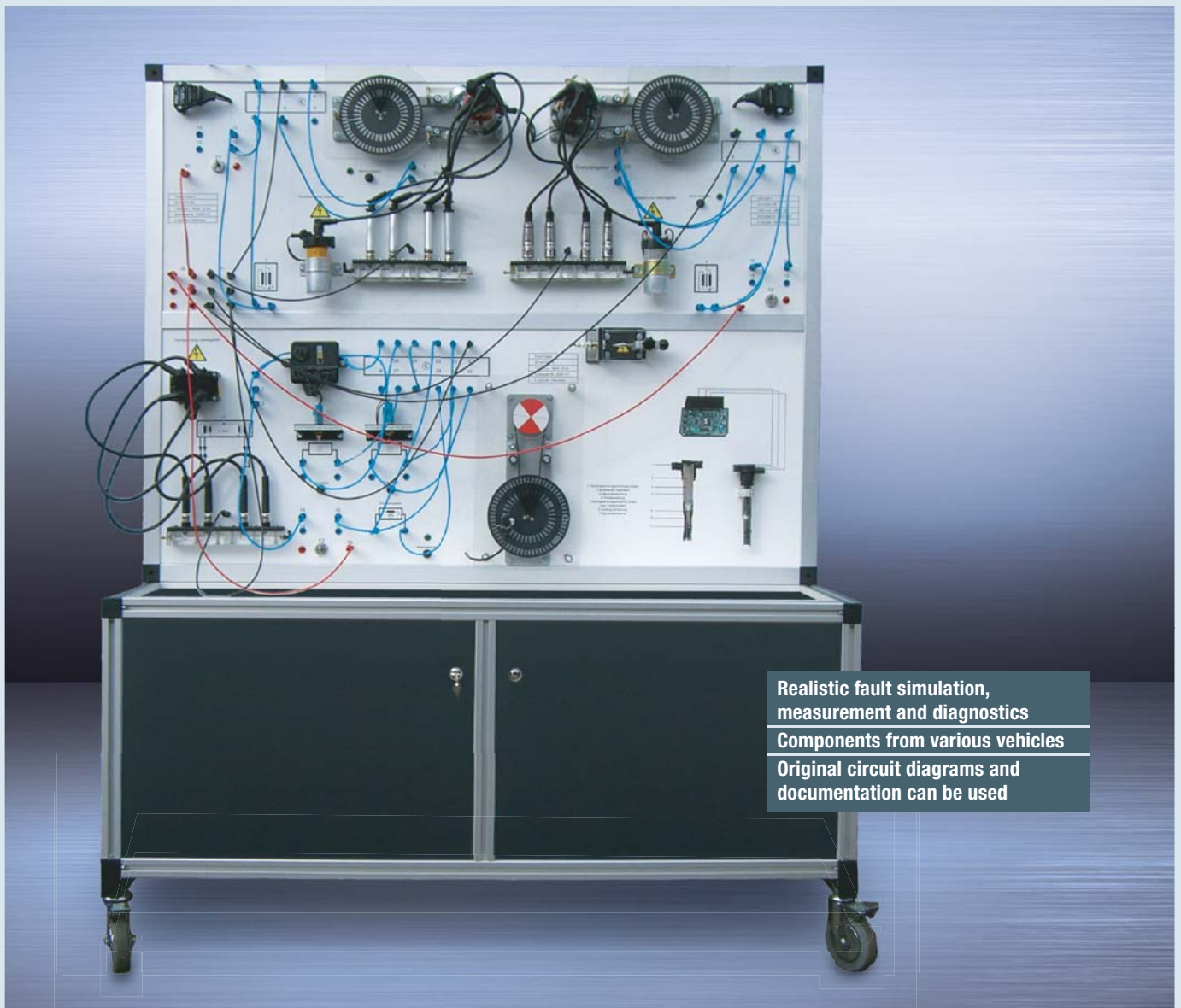

TSZI, TSZH and Fully Electrical Ignition with Resting High Voltage Distribution

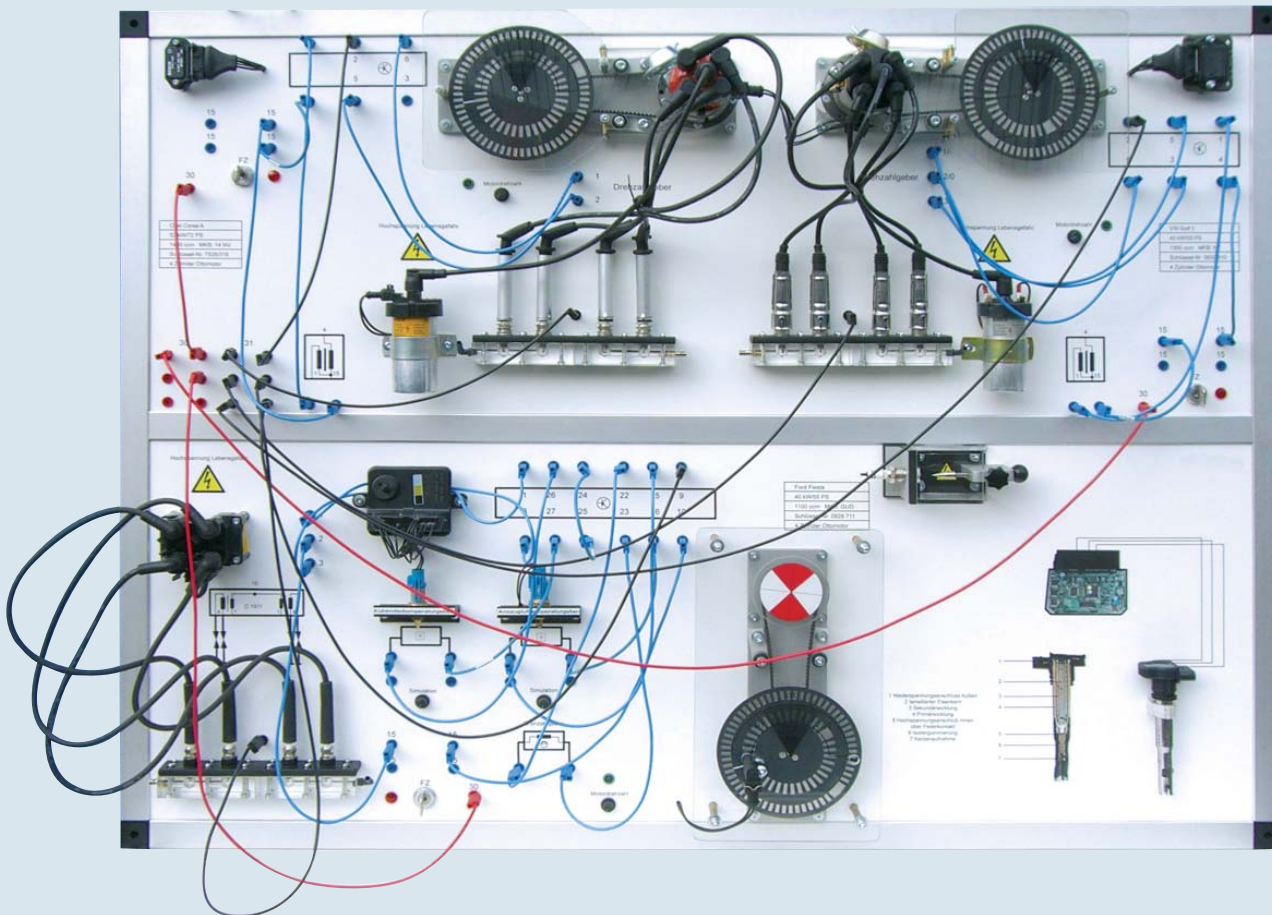

Standard series equipment:

- Ready-to-use and movable functional model with lockable base cabinets
- Voltage-stabilised switched mode power supply (fitted in base cabinet)
- Connection cables with safety sockets
- Three functional units that operate independently of one another with manual speed control
- Spark plugs in Makrolon blocks with overpressure and underpressure connections
- Spark gap simulation
- Front can be labelled with marker pen

Possible uses:

- Checking and repairing mechanical, electrical and electronic circuits and systems
- Working with maintenance and circuit diagrams
- Measuring electrical variables and signals, as well as their documentation and evaluation
- Identifying individual components and learning about their operating characteristics and parameters
- Working with electrical and mechanical measurement and test equipment
- Checking components to decide which repair measures are necessary (if any)

Learning objectives:

- Working with maintenance schedules, wiring diagrams, symbols, terminal designations, wires and wiring connections
- Naming mechanical, electrical and electronic components, assembly groups and systems
- Checking and repairing mechanical, electrical and electronic circuits and systems
- Selecting and using mechanical and electrical measuring and testing equipment
- Measuring and evaluating electrical variables and signals
- Documenting work results and evaluating by comparing them with calculated variables and manufacturer specifications
- Documenting, analysing and evaluating measured values, signals and error protocols
- Examining individual components and making a decision about necessary repair measures

Scope of delivery:

Ready-to-use and movable functional model, including voltage-stabilised 12 V switched mode power supply, datasheets, circuit diagrams and operating manual

Specifications:

Dimensions: L x W x H 1600 x 800 x 1950 mm
Weight: approx. 220 kg
Electrical connection: 110 V/240 V mains connection

Article

TSZI, TSZH and fully electrical ignition with resting high voltage distribution

Order-No.

82-77403

Engine Technology/Vehicle Diagnostics

Diesel Engine with Common-Rail Technique – DaimlerChrysler A Class

A superlative engine with the latest technique. The engine is driven by a 220V geared motor, all the assemblies also run. The start can be engaged, the transmission shifted.

The following are cutaway:

- cylinder head (with 16 valves)
- cylinder block
- crankcase
- oil pan
- one piston with cooling duct
- oil injection cooling for pistons
- hydraulic valve tappet
- oil pump
- chain case
- generator (internally ventilated)
- starter
- exhaust gas re-circulation valve
- turbocharger
- intake manifold
- air filter box
- high-pressure pump
- one injector
- feed pump
- rail manifold
- valve cover
- air-mass sensor
- oil filter with heat exchanger
- thermostat
- modern single-vane vacuum pump
- 5-gear transmission and differential

All actors and sensors are available and connected to the cable tree.

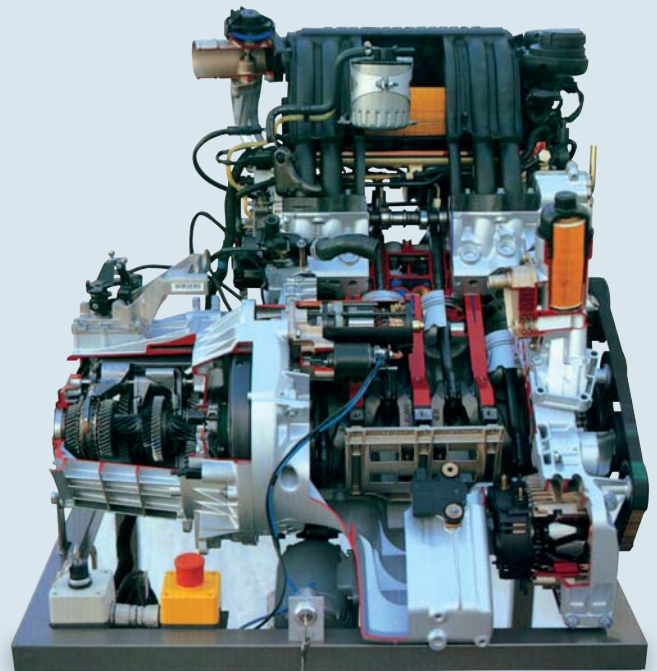

Order-No.

82-77127

Petrol Engine with Injection – DaimlerChrysler A Class

New construction with the latest technique. The engine is driven by a 220V geared motor, all the assemblies also run. The start can be engaged, the transmission shifted.

The following are cutaway:

- cylinder head
- cylinder block
- crankcase
- oil pan
- one piston
- roller valve lever with clearance compensation element
- oil pump
- chain case
- generator (internally ventilated)
- starter
- intake manifold
- air filter box
- double ignition coil
- electronic control unit
- actuator
- throttle valve
- valve cover
- oil filter
- thermostat
- air-mass sensor
- 5-gear transmission and differential

All actors and sensors are available and connected to the cable tree.

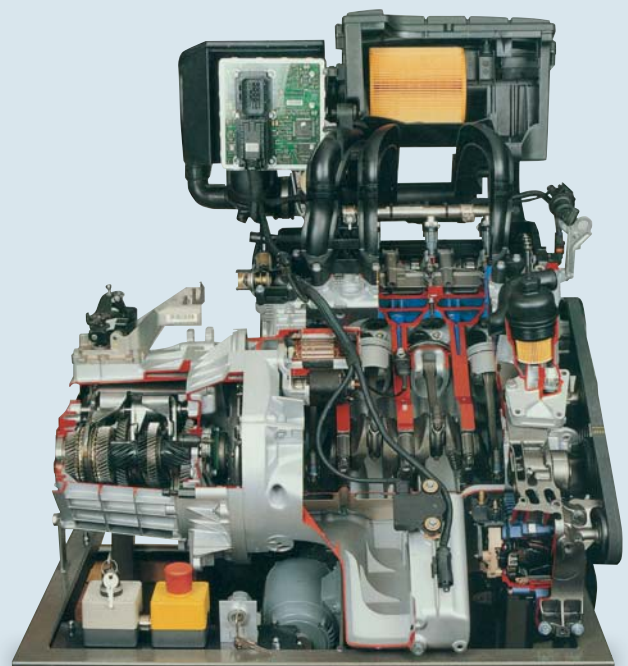

Order-No.

82-77128

Functional Model SSC (Small-Size-Car)

Our training vehicles from the current Volkswagen model range have been specially prepared for vocational training. Models from the current Golf 7 range serve as the basic vehicle here.

Alongside use at vocational training centres, these methodically prepared training vehicles are also used within the scope of practical teaching at vocational schools/colleges. All versions of the models supplied with petrol or diesel engines, as well as the manual and DSG gearbox options, are exactly the same as Volkswagen's current series production models. This makes it possible to perform training using state-of-the-art vehicles. The SSC is fully functional with full diagnostic capability.

As standard, fault switching can be locked in the glove compartment:

Using a fault circuit fitted in the glove compartment, various faults can be simulated and their localisation and rectification can be both learned and practised in real-world conditions. The standard equipment includes 20 practical faults, as they occur in workshops on a day-to-day basis. It goes without saying that multiple switchings are possible. In this way, the trainers can determine the level of difficulty of the troubleshooting themselves. An additional fault circuit box with 20 further faults is also available as an optional extension.



SSC functional model



Door modules for easier handling and accessibility

To avoid installation work and improve the accessibility of components and control equipment, the original driver and passenger doors have been replaced by door modules. All components and control systems of the respective door are fitted in a way that allows them to be measured and isolated here. Components from the rear section of the original vehicle that has been removed, such as the brake system with wheel speed sensors, fuel tank, rear lights, boot lid lock etc., are fitted in easily accessible locations in the footwell and on the back.

Vehicle Diagnostics

Training Vehicle/Functional Model

Functional Model VW Golf 7

The Golf 7 functional model training vehicle from the current modular transverse matrix (MQB) of Volkswagen AG is fully functional. Alongside all troubleshooting and diagnostic work, it can also be used for power measurements on roller dynamometers, wheel alignment in chassis analysis systems and various other applications.

All important fault and diagnostics points in the interior are exposed and have been made accessible. Among other things, this makes it easier to check components of the restraint system, seat adjustment, electric windows or the central locking system and thereby also to get a better feel for their position and function. This means that all necessary measurements can be easily carried out using a multimeter or oscilloscope on components and control units, without having to carry out any installation work. This makes it easier to fully understand the functions of vehicles, while also simplifying the troubleshooting process.

An integrated fault circuit box with 20 faults is fitted to the functional models as standard. This allows real-world workshop situations to be processed in a very short time and the necessary troubleshoot-

ing/fault localisation routines to be performed step-by-step. An optional extension is also available for the integrated fault circuit, offering 20 additional faults.

Optional, factory-fitted measurement boxes with control equipment adapter for the engine management system or the ABS/ESP control unit facilitate non-destructive measurements without the need to continually connect/disconnect the sensitive plug connections on control equipment with lots of PIN connections.

A standard workshop diagnostic system can be used to perform self-diagnostics and encoding on all fitted control devices. The connection to diagnostic equipment is established using the 16-pin connector as per the VW ISO/OBD standard.



Functional model, Golf 7
(example image)

Didactically prepared vehicle with open inner area
Easy access to relevant test ports and control units
Completely functional and ready for diagnoses



Rear view (example image)



Functional Models

Engine and gearbox

As a general rule, all drive versions available in series production can be supplied. When placing an order or sending a request, please specify the desired engine and gearbox. We will make every effort to meet your requests.



Driver's side (example image)



Boot lid (example image)



Fault box (example image)



Vehicle (example image)

Additional fault circuit boxes and an ABS test box (optional):

On request (and for a surcharge), the vehicle can be equipped with an additional fault circuit box that contains 20 extra faults and/or an active test box connected in parallel for the ABS system. The connections are integrated into the original vehicle's cable harness. The fault circuit boxes and the ABS test box cannot be retrofitted. Please take this into consideration when ordering a vehicle. Using test boxes and fault circuit boxes prevents potential

sources of faults from occurring over time due to the constant connection of plugs to components and disconnection of control equipment plugs.

Fuel	Order-No.
VW functional model category I	82-98584
VW functional model category II	82-98585
VW functional model category III	82-98586

Article	Order-No.
Functional Model VW-SSC Golf 7 TDI	82-85918
Functional Model VW-SSC Golf 7 TSI	82-85783

Diesel	Order-No.
VW functional model category I	82-98623
VW functional model category II	82-98624
VW functional model category III	82-98625

Recommended Accessories (optional)

Article	Order-No.
VW test box ABS/ESP MQB	82-83793
VCDS pro basic kit	82-82251
VW engine compartment test box	82-92970
VCDS pro maxi service case	82-86596
VW Fault circuit extension with 20 faults	82-89782
Measurement boxes with adapter for VW engine management system, 154-pin (Bosch ECU)	82-74250
Measurement boxes with adapter for VW engine management system, 196-pin (Simos ECU)	82-83791

Automotive electrics and networked systems - from the basics to the professional topics

Electrical vehicle systems are amongst the most complex systems to be found in vehicles. Diagnostics and troubleshooting in these systems are presenting ever greater challenges for workshop personnel. The use of special measuring and test equipment as well as sophisticated diagnostics systems requires specific expertise in vehicle electrics and in the complete data communication system structure. In addition to the conventional 12 V on-board power supply system, vehicles are increasingly featuring high-voltage systems in the drive system and, more recently, the comfort system too (HV air-conditioning system). This means that work on electrical vehicle systems must now also be performed in line with the mandatory safety measures set out in DGUV 200-005 and must have the required authorisation.

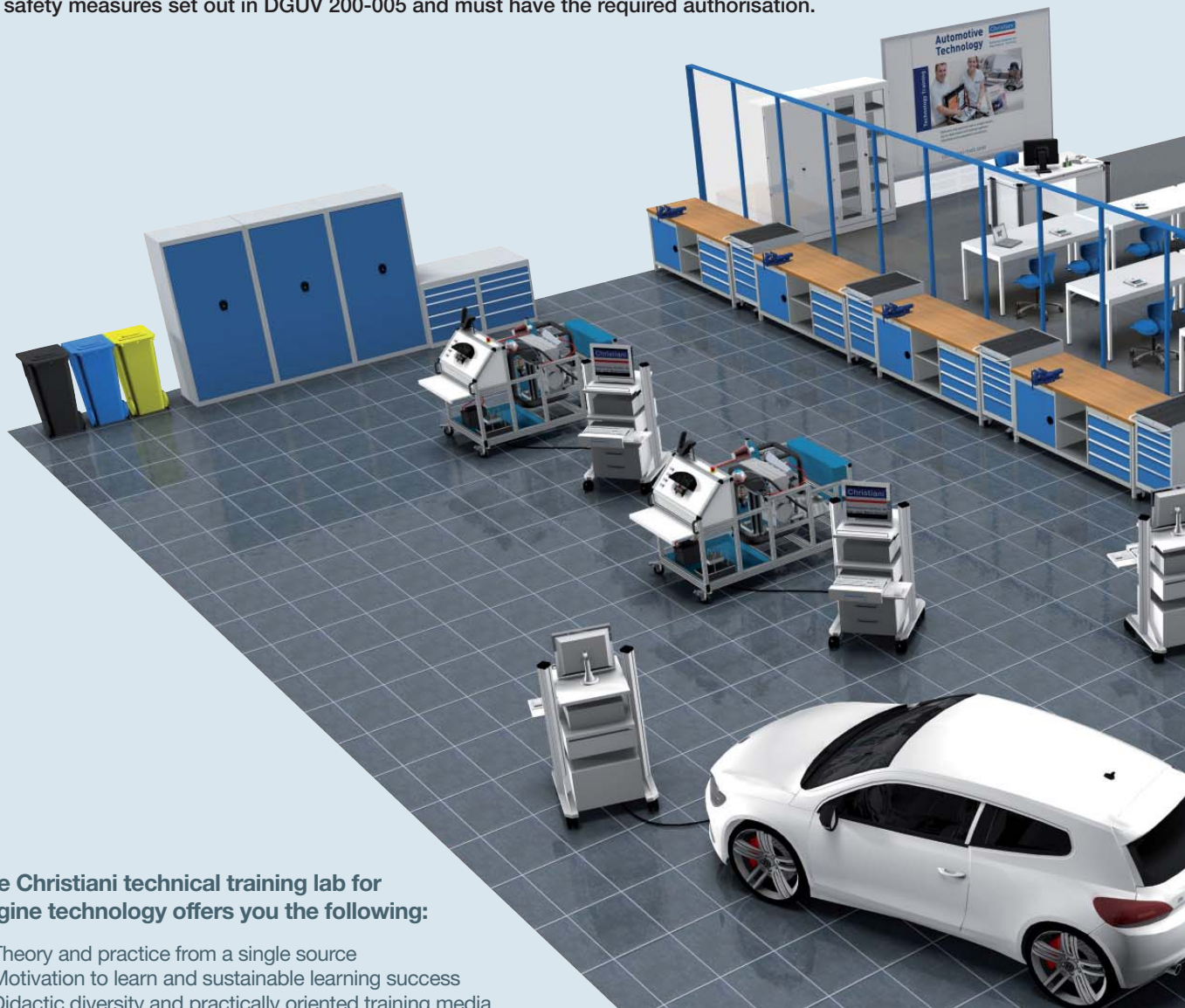

The Christiani technical training lab for engine technology offers you the following:

- Theory and practice from a single source
- Motivation to learn and sustainable learning success
- Didactic diversity and practically oriented training media
- Strong partnerships with industry
- Professional consulting – from the planning stage, all the way up to implementation



Experience the Christiani technical training
labs in 3D and 360° all-round view
www.christiani-training-lab.com



COMPACT INFO

Technical Training Lab for Automotive Electrics

Example configuration for 16 workplaces

- An HV vehicle with LED lights
- A standard vehicle
- Petrol/diesel engine functional models
- Central electrics with H7 and bi-xenon adaptive front lighting functional models/training stands
- Diagnostics systems with oscilloscope
- Test and measuring equipment for HV vehicles
- Personal protective equipment (PPE) for work on HV vehicle drilling machines

Suitable for:

- Automotive mechatronic engineer for passenger cars
- Automotive mechatronic engineer for passenger cars, specialising in systems and highvoltage engineering

Topics/Learning objectives

- Working with circuit diagrams and repair information systems
- Using appropriate measuring and test equipment
- Testing and measuring electrical variables
- Diagnostics and troubleshooting on on-board power supply systems
- Diagnostics and troubleshooting on lighting systems
- Diagnostics and troubleshooting on start and charging current systems
- Using diagnostics systems for troubleshooting
- Modifying, coding and adapting control units
- Instruction on HV vehicles
- Safety regulations for working on electrical systems with a voltage > 30 V AC and > 60 V DC
- Using personal protective equipment (PPE) and HV-compatible measuring and test equipment

Vehicle Electrics/Electronics

Training Stand/Functional Model

CAN-Bus Function Wall – VW Golf 6

The CAN-bus function wall was created from original components of the VW Golf 6. Particularly noteworthy in this conception is the realistic representation of the components and their connections. In contrast to comparable systems no banana plugs or standard connectors are here used for the links between the original components, but the original compounds from the vehicle. This allows the use of original manufacturer's documents and schematics of Volkswagen AG and measurements, fault simulation and diagnosis in real conditions.

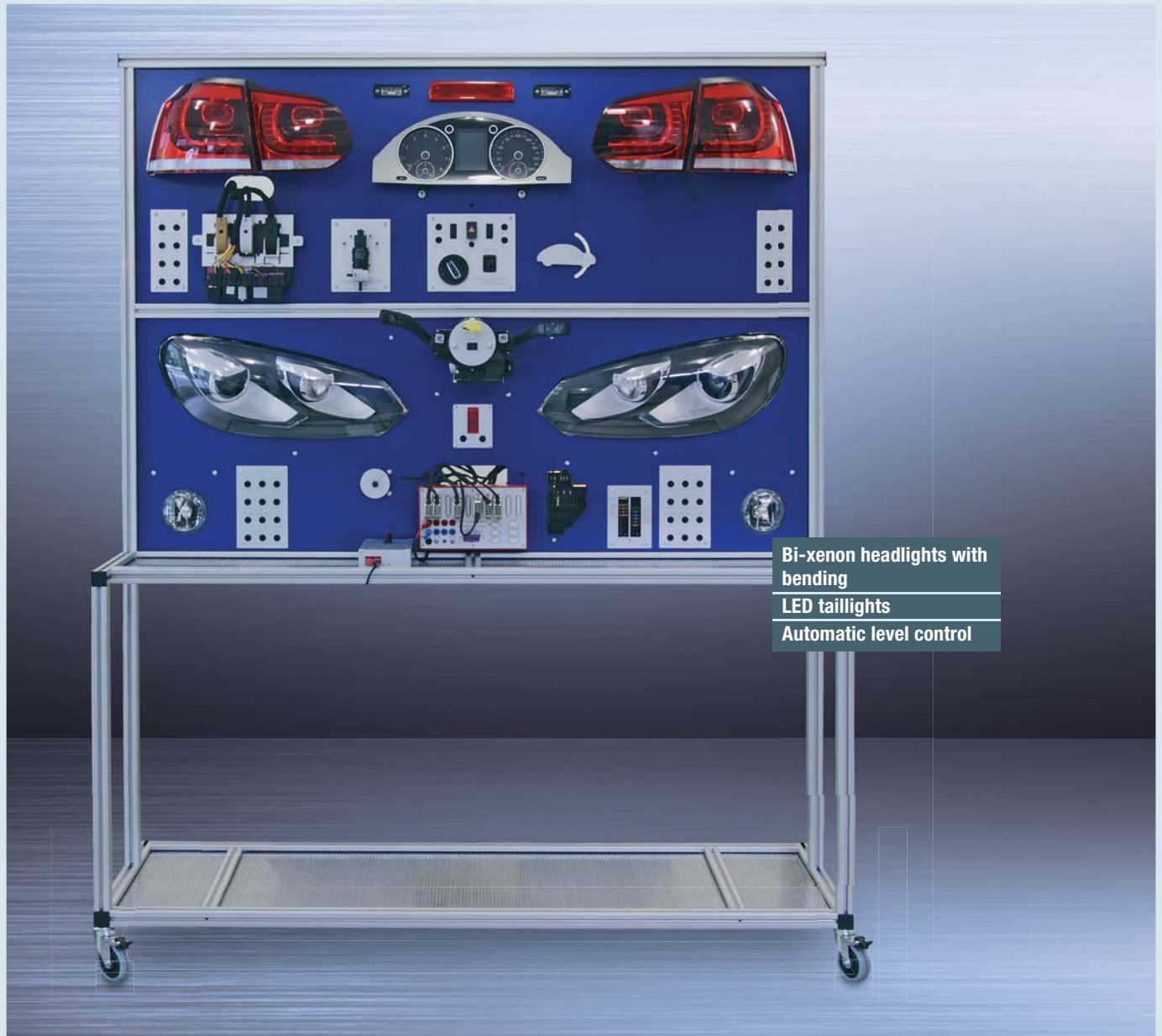

The CAN function box serves the CAN-bus function wall as a central interface, allowing additional connectivity accessories. For this, the function box contains 10 parallel interfaces for K-Line, LIN-bus and all other CAN-bus connections and connections for the associated power and ground connection. The supply of the individual components can be controlled via two LEDs. To avoid short-circuit damage the parallel ports are covered with 2 fuses. To make the signals on the CAN-bus not only visible as a voltage, but also the contents of CAN messages with the associated control

device addresses (identifiers) to be read out, the CAN and LIN buses, as well as the K-line are 7-pin D-sub connectors brought out separately. This makes possible the messages are retrieved or read in plain text with a CAN or LIN interface. The connection of diagnostic equipment is carried out via the 16-pin OBD connector to VAG standard. To supply the function wall, a voltage-regulated 12 volt switching power supply with a sufficient output power (min. 200 watts) is recommended. Alternatively, a 12 volt vehicle battery (60 amps 12 volts) can be used with sufficient capacity.

CAN-Bus Function Wall – VW Golf 6



Standard series equipment:

- Headlamp combination with Bi-Xenon Headlights with cornering and vehicle position sensor
- LED taillights
- Additional brake light
- License plate light
- Instrument cluster (Highline equipment)
- Front and rear fog lamp
- BCM (Body Control Module) control unit (Highline equipment)
- Original Sicherungskästen
- Wiper Motor
- Wash pump for front and rear wipers
- CAN-LIN function box with parallel sockets for Component, connectors for CAN interface and OBD connector
- Integrated Fehlerschaltbox with 16 errors circuits (lockable)
- Steering column combination switch with control unit
- Diagnostic Interface (Gateway)
- Lights switching center
- Reversing light
- Component measuring points with connection sockets for oscilloscope / multimeter
- „Restbussimulator“ with speed control and device simulation

Possible uses:

- Working with circuit diagrams, circuit symbols, terminal designations, wires, connectors
- Use of the workshop conventional diagnostic equipment
- Involving problem-solving strategies and alternatives in the diagnosis
- Check individual components and decide on necessary repair measures
- Coding ECUs, customizing software versions and checking of data communication lines, in compliance with legal and manufacturer-related provisions

Learning objectives:

- Naming of electrical and electronic components, assemblies and systems
- Testing and maintenance of electrical and electronic circuits
- Selecting and using electrical measuring and testing devices
- Measurement and evaluation of electrical quantities and signals
- Documenting work results and evaluate by comparing with calculated values and manufacturer specifications

Scope of delivery:

Complete ready-to-use and immediately deployable training stand with fault simulation, operation manual, technical documentation and circuit diagrams

Specifications:

Power connection: 110/240 Volt Power supply
 Dimensions: L x W x H 1400 x 800 x 1,950 mm
 Weight: 80 kg

Article	Order-No.
CAN-Bus Function Wall - VW Golf 6	82-81951
More information at: www.christiani-international.com/81951	

Recommended Accessories (optional)

Article	Order-No.
Convenience module	82-81952
Rain/light sensor	82-81953
Trailer module	82-75351
Laboratory Switching Mode Power Supply	82-77196
VCDS pro basic kit	82-82251
Digital storage oscilloscope	82-58053
PCAN Interface/ISO adapter with USB connection	82-74734
PCAN Explorer	82-74735

Automotive Electrics/Electronics Training Stand/Functional Model

CAN-Bus Function Wall – VW Golf 5

The CAN-bus stand for performing experiments was created using original components from the VW Golf 5. The realistic representation of the components and their connections is worthy of special mention with this design. In contrast to comparable systems, no bunch plugs or standardised plug connections are used for the connections between the original components here. Instead, only original connections from the actual vehicle are used. This allows the use of original manufacturer documentation and circuit diagrams, supplied by Volkswagen AG, while also allowing measurements, fault simulations and diagnostics to be performed in real-world conditions.



The function wall's CAN function box serves as the central interface and also provides additional connection options for accessories. To facilitate this, the function box includes 10 parallel interfaces for the diagnostic cable, LIN-bus and all other CAN-bus connections, as well as connections for the accompanying power supply and earth connection. The supply of the individual components can be monitored on two LEDs. To prevent short-circuit damage, the parallel connections are also safeguarded with two fuses.

As well as the diagnostic cable, individual 7-pin sub-D sockets are provided for the CAN and LIN-buses to not only allow the signals to be visualised as voltages on the CAN-bus, but also to be able to

export the contents of the CAN messages using the accompanying control unit addresses (identifiers). When used with a CAN or LIN interface, these allow the messages to be queried/exported in plain text.

The connection to diagnostic test equipment is established using the 16-pin OBD connector as per the VAG standard. A voltage-stabilised 12 V switched mode power supply with sufficient power output (min. 200 W) is recommended for supplying voltage to the function wall. Alternatively, a 12 V car battery with sufficient capacity can be used (12 V 60 AH).

CAN-Bus Function Wall – VW Golf 5



Standard series equipment:

- Headlight combination H7
- Rear lights combination
- Rear window brake light
- License plate light
- Instrument cluster
- Front fog light
- Rear fog light
- Vehicle electrical system control unit
- Safety plate
- Wiper motor (LIN-BUS)
- Washer pump for front and rear wipers
- CAN-LIN function box with parallel sockets for components, sockets for CAN interface, power supply connections and OBD connection
- Integrated fault switching box with 14 fault switches (lockable)
- Steering column combination switch with control unit
- Diagnostic interface (gateway)
- Light switch centre
- Reversing lights
- Component measurement points with connection sockets for oscilloscope/multimeter

Learning objectives:

- Naming electrical and electronic components, functional units and systems
- Checking and repairing electrical and electronic circuits
- Selecting and using electrical measuring and testing equipment
- Measuring and evaluating electrical variables and signals
- Documenting work results and evaluating by comparing with calculated variables and manufacturer specifications

Possible uses:

- Working with wiring diagrams, symbols, terminal designations, wires and wiring connections
- Making use of the possibilities offered by commonly used workshop diagnostic devices
- Making use of problem resolution strategies and/or alternatives during diagnosis
- Examining individual components and making a decision about necessary repair measures
- Encoding control units, adapting software statuses and checking data communications wires, taking account of legal stipulations and manufacturer specifications

Scope of delivery:

Fully operational and ready-to-use training stand with fault circuit, operating manual, technical documentation and circuit diagrams

Specifications:

Dimensions: L x W x H 1400 x 800 x 1950 mm

Weight: approx. 80 kg

Electrical connection: 110 V/240 V mains connection

Article	Order-No.
Training Stand/Functional Model CAN-Bus Function Wall – VW Golf 5	82-85767

Recommended Accessories (optional)

Article	Order-No.
VW-CAN convenience module	82-85530
Rain/light sensor	82-81953
Trailer module	82-75351
Switched mode power supply DC 1 - 16 V 0 - 40 A	82-77196
VCDS pro basic kit diagnostic system	82-82251
Digital storage oscilloscope 20 MHz/digital multimeter	82-58053
PCAN Interface/ISO adapter with USB connection	82-74734
PCAN Explorer 4 – comprehensive CAN monitor for Windows®	82-74735

Automotive Electrics/Electronics Training Stand/Functional Model

Basics of Electrical Systems in Motor Vehicles – VW Golf 4

The training stand has been specifically designed for demonstrating the basics of electrical systems in motor vehicles. The components used for the apparatus are based on the Golf 4 and are both fitted and connected to one another exactly as they were in the original vehicle.

The trainee's task is to lay the entire cabling of the components in a lighting system as per the end-to-end circuit diagram and demonstrate that all of these components are working correctly through commissioning. An integrated fault circuit with remote control introduces the trainees to systematic troubleshooting in a step-by-step approach.

Since the original DIN switching symbols and DIN 72522 terminal designations are used, it is possible to wire up the entire vehicle training stand exactly as shown in the circuit diagram. All compon-

ents are equipped with the specific plug-in sockets with digital diagram printout on the base plate. This guarantees the same cabling structure at all times.

Functional assemblies such as light switches, headlights, wipers, etc. can also be wired up individually as an initial training exercise. Working in groups, all consumers and switching elements can then be connected to one another in such a way that the relatively complex system wiring diagram and interactions between the individual elements are easier to understand.

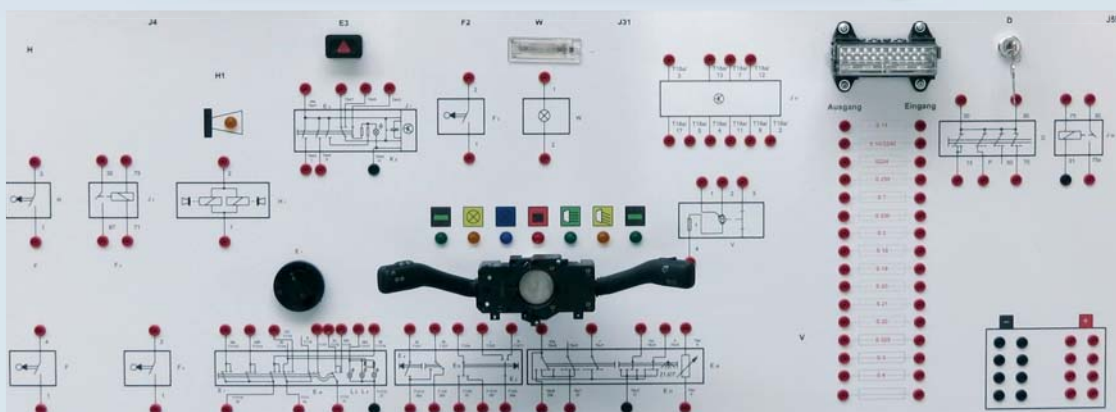
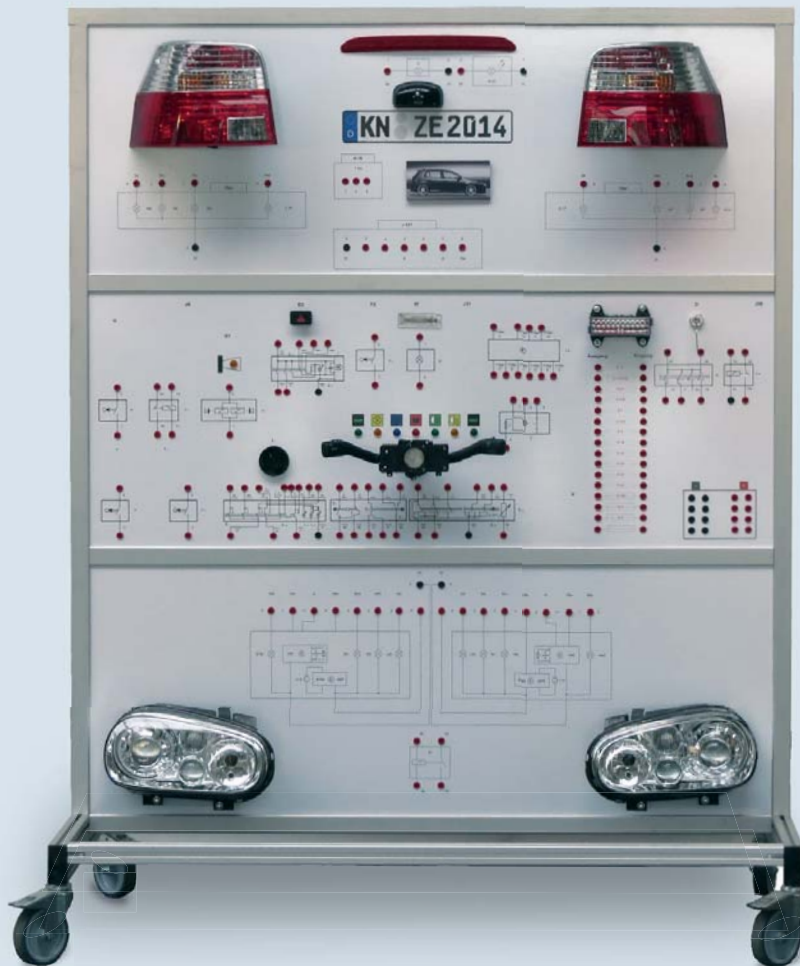

Basics of Electrical Systems in Motor Vehicles – VW Golf 4

Standard series equipment:

- Ready-to-use and movable functional model
- Voltage-stabilised switched mode power supply
- All connection leads required (laboratory cables with 4 mm safety sockets)
- Front can be labelled with marker pen
- Fault circuit with eight faults and remote control
- Xenon headlights with automatic headlight beam throw adjustment, fog lights and original rear lights, ignition starter switch, steering column switch, hazard warning lights system, level sensor, wiper motor, light switch, brake light switch, additional brake light, rear lights, number plate light, interior light, power distribution box, relay, door contact switch, horn

Possible uses:

- Working with wiring diagrams, symbols, terminal designations, wires and wiring connections
- Making use of the possibilities offered by commonly used workshop diagnostic devices
- Making use of problem resolution strategies and/or alternatives during diagnosis
- Examining individual components and making a decision about necessary repair measures
- Troubleshooting in electrical circuits

Learning objectives:

- Naming electrical and electronic components, functional units and systems
- Checking and repairing electrical and electronic circuits
- Selecting and using electrical measuring and testing equipment
- Measuring and evaluating electrical variables and signals
- Documenting work results and evaluating by comparing with calculated variables and manufacturer specifications

Scope of delivery:

Ready-to-use and movable functional model, including voltage-stabilised 12 V switched mode power supply, datasheets, circuit diagrams and operating manual

Specifications:

Dimensions: L x W x H 1600 x 800 x 1950 mm

Weight: approx. 140 kg

Electrical connection: 110 V/240 V mains connection

Article	Order-No.
Basics of Electrical Systems in Motor Vehicles – VW Golf 4	82-95992
Trailer socket extension	82-95998
Preheating system extension	82-95999

Recommended Accessories (optional)



Digital multimeter for motor vehicle applications

Speed measurement, closing angle measurement, Frequency measurement, of the pulse-pause ratio and pulse duration, Temperature measurement. The multimeter is equipped with high-power fuses for the current measuring ranges and comes with a dust-proof and waterproof housing.

Order-No.

82-58450



Storage oscilloscope

This combination of one digital Two-channel/20 MHz storage oscilloscope and one true RMS multimeter represents the ideal solution for any measurement task. The creative shortcut design simplifies operation, the high-resolution 3.8" TFT colour display (640 x 480 pixels - 65,535 colours) makes it easy to observe curves, while the lithium-ion battery guarantees continuous operation with its long service life.

Order-No.

82-58053



Measurement cable kit

Measurement cable kit for use with the oscilloscope Order no. 58053. For measuring signals and values on engine training stands with and without a test box, as well as on CAN-bus training systems with measuring tips, laboratory cables and adapters with 4 mm measuring sockets.

Order-No.

82-80968

Automotive Electrics/Electronics Training Stand/Functional Model

Central Automotive Electric H7 - VW Golf 6

This training stand is designed for practical use in appropriate learning fields in the german dual system. In addition to the wiring circuit diagram to the diagnostics and programming using workshop tester via OBD possible. The necessary between the network control unit and the components installed cable connections must be made according to circuit diagram by the trainees themselves. For better identification of the CAN connections between the control

devices laboratory cables are supplied with 4 mm safety sockets and different color coding. The inputs and outputs of the installed components are displayed in digital printing on the front panels. A special film enables to write on the plates with white board marker. This ensures high level of practicality. As circuit diagram, a specially drawn for this system rolling plan or consisting of single pages VW original circuit diagram can be used.



Training stand H7



Training stand Bi-Xenon

Central Automotive Electric Bi-Xenon - VW Golf 6

The following components are installed:

- Network control unit
- Steering column control unit with switch unit
- Diagnostic Interface (Gateway)
- Headlamp range adjustment manually
- Light switch
- Wiper motor
- H7 Headlight
- Fog lamps with associated control unit
- Static Cornering Light
- Rear lights including fog light and reversing lights (incl. reversing lamp switch)
- High-level brake light
- Brake Light Switch
- Hazard switch and interior light with door contact switch

Standard series equipment:

- Out-performance and wheeled functional model
- Voltage Regulation switched mode power supply
- All required connecting cables (test lead with 4 mm safety sockets)
- Writable Front page
- OBD diagnostics interface

Possible uses:

- Working with circuit diagrams, circuit symbols, terminal designations, wires, connectors
- Making use of the options of the conventional workshop diagnostic equipment
- Inclusion of problem-solving strategies and alternatives in the diagnosis
- Check individual components and decide on necessary repair measures
- Coding ECUs, customizing software versions and checking of data communication lines, in compliance with legal and manufacturer-related provisions
- Creating the cable connection according to circuit diagram
- Troubleshooting the central electrics via OBD diagnostic interface

The bi-xenon training stands have the same basic features as the H7 training stand.

In addition, the following components are installed:

- Bi-xenon headlights including the necessary control devices
- Vehicle position sensors for controlling the automatic headlights height adjustment
- Engine speed simulation, speed and steering angle simulation for bend lighting

With the bi-xenon functional model not only the signals and data of the convenience CAN-bus but also that of the CAN-bus drive can be displayed. Also the zero position setting of the headlights via the OBD diagnostic port is possible.

Learning objectives:

- Naming of electrical and electronic components, assemblies and systems
- Testing and maintenance of electrical and electronic circuits
- Selecting and using electrical measuring and testing devices
- Measurement and evaluation of electrical quantities and signals
- Documenting work results and evaluate by comparing with calculated values and manufacturer specifications

Scope of delivery:

Ready-to-use and wheeled functional model incl. voltage regulated 12 volt switch mode power supply, data sheets, circuit diagrams and operating instructions. Alternatively, the training stand can also be operated with a commercial vehicle battery. The delivery also includes all necessary connecting cables, the manual with practical examples, information sheets and worksheets, as well as consistently drawn and laminated diagram

Specifications:

Power connection: 110/240 Volt Power supply
Dimensions: L x W x H 1600 x 800 x 1,950 mm
Weight: approx 140 kg

Article	Order-No.
Training stand/Functional model VW Central electrics H7	82-77162
Training stand/Functional model VW Central electrics with Bi-Xenon	82-77171
Expansion trailer socket	82-96103

Training Stand/Functional Model: Starter Motor Generator



The training stand has been designed for performing measurement exercises and troubleshooting, as well as for learning how an alternator and pre-engaged starter motor work. The parts installed are printed in a list on the front panel and also carry the respective electrical switching symbol and circuit diagram. There are measuring points with 4 mm safety measuring sockets within the circuit diagram. The front panel can be written on using water-soluble pens.

The 3-phase alternator has been specially prepared and various faults can be activated via an integrated fault circuit to practice diagnostic methods and fault interpretation. Voltages, currents, control responses and redundancies can be measured, recorded and evaluated using a multimeter or oscilloscope via the measuring sockets in the front panel.

The 3-phase alternator is driven via a 230 V AC motor with frequency converter. In conjunction with a freely variable speed control and various switched consumers, this makes it possible to simulate all functions of the alternator and the charge controller. Real-world operating situations are thereby created and the kinds of measurements typically taken in practice can be performed. A digital display is fitted for this.

In addition to this, the stand is equipped with a vehicle battery and a starter. The starter is functional. It is equipped with a mechanical brake to simulate load conditions. An ammeter with current probe can be used to demonstrate the change in power consumption under load, as well as the battery discharge that this causes.

There is a selector switch between the circuit diagram of the pre-engaged starter motor and the 3-phase alternator. Depending on the position, it is possible to work either with the starter or with the alternator.

While work is being performed on the 3-phase alternator, the battery is charged, as it would be in real-world conditions. However, this obviously requires ALL fault switches and consumers to be switched off.

A special measuring instrument (battery tester) is provided for diagnosing the charge status of the battery. No multimeter or oscilloscope is included in the scope of supply.

Standard series equipment:

- Ready-to-use and movable functional model
- Connectable consumers for load simulation on the alternator
- Mechanical brake for load simulation on the starter
- Front can be labelled with marker pen
- Fault circuit with 11 faults

Possible uses:

- Working with wiring diagrams, symbols, terminal designations, wires and wiring connections
- Making use of the possibilities offered by standard workshop measurement and testing equipment
- Making use of problem resolution strategies and/or alternatives during diagnosis
- Examining individual components and making a decision about necessary repair measures
- Troubleshooting in electrical circuits

Learning objectives:

- Naming electrical and electronic components, functional units and systems
- Checking and repairing electrical and electronic circuits
- Selecting and using electrical measuring and testing equipment
- Measuring and evaluating electrical variables and signals
- Documenting work results and evaluating by comparing them with calculated variables and manufacturer specifications

Scope of delivery:

Ready-to-use and movable functional model, including 12 V vehicle battery, datasheets, circuit diagrams and operating manual

Specifications:

Dimensions: L x W x H 1400 x 800 x 1950 mm

Weight: approx. 140 kg

Electrical connection: 240 V mains connection (110 V on request)

Article

**Training Stand/Functional Model:
Starter Motor Generator**

Order-No.

82-85568

Specially developed for educational establishments – the AVL DiTest HV-Safety 2000 and training case

In future, every workshop will have to work on a significant number of hybrid and electrical vehicles. Various studies have indicated that the next few years will see rapid growth in the electrification of vehicles. This includes not only hybrid and electrical vehicles but also electrified components such as air-conditioning compressors, power steering and automated start/stop systems. In view of these predictions, it is clear that vehicles of this kind constitute an increasingly significant proportion of everyday operations in workshops.

Guaranteeing the safety and reliability of high-voltage systems in these vehicles is one of the tasks that will need to be faced in future. Testing high-voltage systems is a basic check that needs to be performed during all maintenance and repair work on high-voltage vehicles. These measurements are increasingly gaining in importance for testing authorities because the insulation resistance and equipotential bonding are subject to a certain amount of deterioration over time.

The AVL DiTest HV-Safety 2000 and training case has been developed to reduce the heightened safety risk during maintenance. It guarantees the highest possible level of safety for your trainees and course participants, as well as practical testing options. Developed specifically for educational establishments, the AVL DiTEST HV-Safety 2000 and training case complies with all safety standards applicable to practical training operations.

The AVL DiTEST HV-Safety 2000 Training Case

Active insulation resistance measurement using the integrated test voltage generator

To test the installation resistance of a vehicle, an external test voltage must be applied. This voltage must be within the range of the electric vehicle's battery voltage. HV Safety 2000 generates the necessary voltage automatically and safely without presenting any risk to the user. The entire test is also made available in the test report.

Potential equalisation measurement with four-wire measurement technology – as per unece R100

After completing the work – e.g. replacing a part – the high voltage needs to be re-established without any issues. The UNECE R100 standard defines inspection of the potential equalisation resistance to verify the safety of the HV vehicle. HV Safety 2000 supports this measurement with the prescribed testing current of 1 A.

Possible uses:

- Working with wiring diagrams, symbols, terminal designations, wires and wiring connections
- Activating HV systems, taking into account all requisite safety precautions
- Measurement of isolation from supply and general voltage measurement
- High-voltage insulation resistance measurement (with deactivated HV system)
- Insulation resistance measurement as per SAE J1766 measurement, ECE R100, ISO6469 (with deactivated HV system)
- Potential equalisation conductor measurement

Learning objectives:

- Naming electrical and electronic components, functional units and systems
- Selecting and using suitable measurement and testing equipment
- Testing electrical and electronic circuits, taking into account the requisite safety precautions
- Taking the most important measurements and using the most important measurement methods on HV systems with the requisite safety equipment
- Documenting work results and performing evaluations through comparison with manufacturer specifications

Specifications:

Dimensions: L x W x H 500 x 400 x 250 mm
Weight: approx. 8 kg
Electrical connection: 110 V/240 V mains connection

Standard Multimeterfunctions:

HV Safety 2000 offers all the functions of a digital voltmeter: diode, resistance, capacitance and voltage measurement. The measured values are displayed in easily legible form on the screen of your PC or laptop. This saves the workshop having to invest in various different measurement devices.

Power supply via usa Interface

No additional power supply or battery is necessary. The device is always ready for operation, including generating high voltage for the isolation resistance test and the 1 A current for taking measurements in line with UNECE R100.



Scope of delivery:

- AVL DiTest HV Safety 2000 with accompanying software
- 1000 V red test probe with safety sensor, requires safety gloves to be worn
- 1000 V black test probe with safety sensor, requires safety gloves to be worn
- HV demonstrator with all test voltages relevant for taking measurements on hybrid and electric vehicles
- Transport case with connection socket for 12 V power supply unit (power supply)
- Graphic DIN A0 with hazard warnings and safety regulations

Order-No.

82-95880

Locktronics



An Introduction to motors and generators

This solution allows students to investigate the electrical principles behind motors and generators and is designed to support the teaching of a range of automotive units. It is accompanied by a comprehensive set of curriculum worksheets and supporting documentation to facilitate the learning of this core topic in automotive electrical technology.

Order-No.

82-87163



Electricity, magnetism and materials solution

The kit is supplied with two sets of printable worksheets on CD ROM (around 80 pages) that cover the electrical properties of materials, electricity, and electrical circuits. The solution includes component carriers, base board, power supply, and storage trays. Suitable for Science in the UK at Key Stages 3 and 4.

Order-No.

82-85931



Sensors and control in automotive applications with baseboard

This solution provides an introduction to the role of an Electronic Control Unit. Students use a number of prewritten programs for the MIAC Electronic Control Unit (ECU) to enable them to construct a wide variety of Input - Process - Output circuits using sensors and actuators typically found in vehicles. A full curriculum pack is provided.. The solution includes component carriers, base board, a power supply, and storage trays.

Order-No.

82-86614

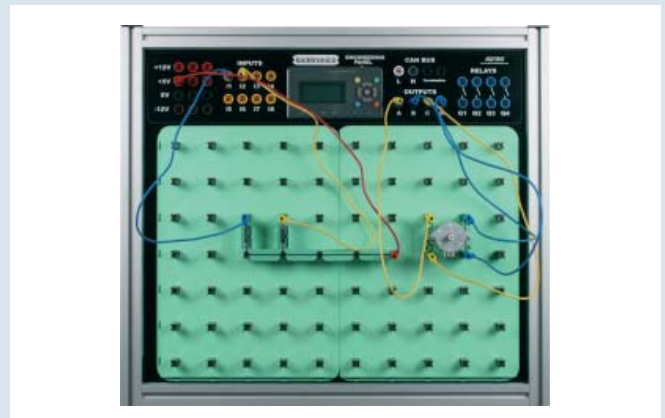

Sensors and control in automotive applications with engineering panel

This solution provides an introduction to the role of an Electronic Control Unit. Students use a number of prewritten programs for the MIAC Electronic Control Unit (ECU) to enable them to construct a wide variety of Input - Process - Output circuits using sensors and actuators typically found in vehicles. A full curriculum pack is provided.. The solution includes component carriers, base board, a power supply, and storage trays.

Order-No.

82-89522

Locktronics



CAN-bus systems and operation solution

This kit allows a fully functioning CAN-bus system, mimicking vehicle operation, to be set up using 4 MIAC Electronics Control Units representing Instrument panel, Front ECU, Powertrain control, and Rear ECU. A fifth MIAC is used for system diagnosis, releasing faults and viewing CAN-bus messages. Students are tasked with setting up a fully working CAN-bus system, inserting faults and using hardware and software tools to understand fault diagnosis procedures and practice. The solution includes component carriers, baseboard, power supplies and storage trays and is supplied with a full curriculum pack including teacher's notes.

Order-No.

82-86516



CAN-bus systems and operation solution with engineering panel

This kit allows a fully functioning CAN-bus system, mimicking vehicle operation, to be set up using 4 MIAC Electronics Control Units representing Instrument panel, Front ECU, Powertrain control, and Rear ECU. A fifth MIAC is used for system diagnosis, releasing faults and viewing CAN-bus messages. Students are tasked with setting up a fully working CAN-bus system, inserting faults and using hardware and software tools to understand fault diagnosis procedures and practice. The solution includes component carriers, baseboard, power supplies and storage trays and is supplied with a full curriculum pack including teacher's notes.

Order-No.

82-89521

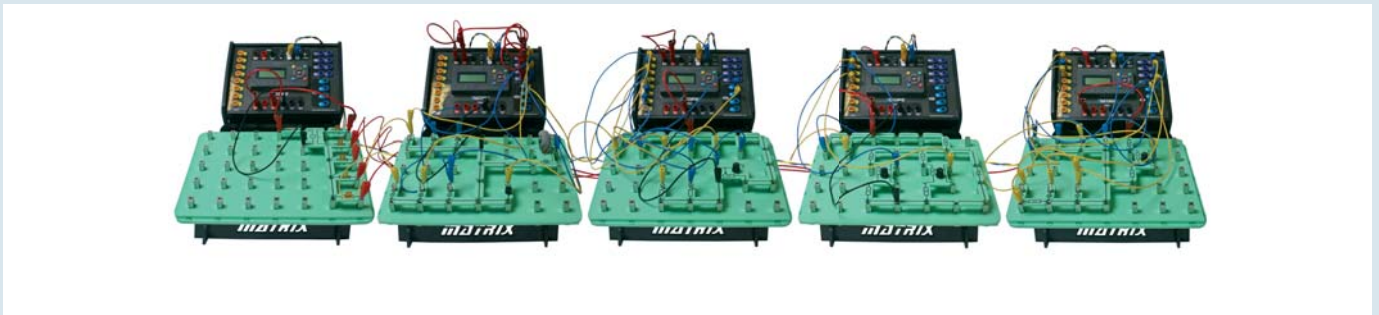

The number of nodes, and how they are configured, varies greatly from one car to another. Different manufacturers use different software, and different messages within their CAN-bus systems. The system used in this course is broadly representative of systems found in cars. Each node consists of an ECU and the associated

circuitry required to control the devices attached to that node. Each node is supplied with power, ground and the two wires, called CAN High (CANH) and CAN Low (CANL). In motor vehicles, these CAN wires are twisted together.

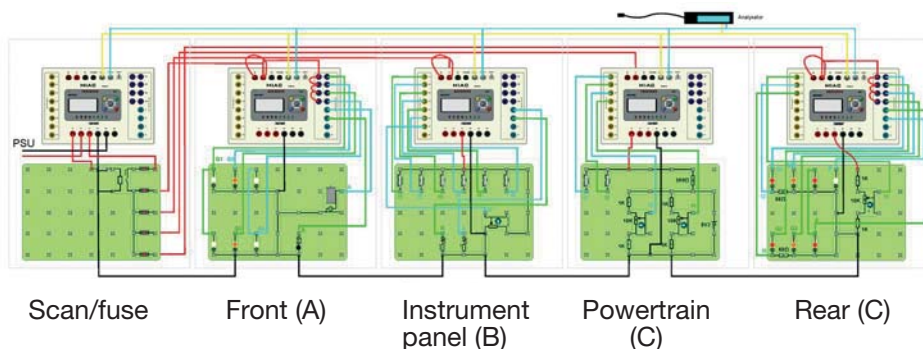

Safety and Comfort Systems

Training Stand/Functional Model

Dual-Zone Climatronic – VW Golf 6

This training stand has been assembled using original components from the Dual-Zone Climatronic system used in the VW Golf 6. Everything is arranged as it would be in the vehicle. The connections of all functionally relevant sensors and actuators, as well as the control devices and components of the cooling circuit are original connections exactly like those found in the vehicle. This makes it possible to work with the manufacturer's original documentation and circuit diagrams. Most of the original components are easily accessible for this or have been exposed to make them accessible.



The on-board diagnostic interface (OBD) allows connection of standard workshop diagnostics systems. This grants access to all fitted control devices and guarantees options such as basic settings of actuators, actuator diagnostics and measured value block exports. Another interface allows connection of up to 14 trainee measuring stations. This guarantees execution of measurement exercises when working in larger groups and using the multimeter or oscilloscope to take measurements and thereby determine the values and various signals.

In addition, the system is equipped with a heating circuit with an electric heating element. This circuit simulates the engine cooling circuit. This makes it possible to generate realistic operating conditions as a way of receiving measured values from the dual-zone control system for diagnostic purposes.

Various components can be manipulated via an integrated and lockable fault circuit with 11 practical faults to perform troubleshooting. One pressure gauge for the high-pressure side and one for the low-pressure side are used to show the pressures under various load conditions. In addition to this, connections are provided for using maintenance stations. The maintenance connections allow climate control maintenance units to be connected. This makes it easy to demonstrate and practice how to extract, clean, evacuate and fill the system with „R134a“ refrigerant.

The air-conditioning compressor is powered by a 3.6 kW 400 V three-phase AC motor and speed-controlled via a frequency inverter. The on-board electrical system is powered via a stabilised 12 V 40 A switched mode power supply. Emissions-free operation allows the unit to be used in training rooms.

Dual-Zone Climatronic – VW Golf 6

Standard series equipment:

- Original dashboard from the Golf 6
- Complete Climatronic system with all accompanying control units
- Electric heating rod for simulating the engine's cooling circuit
- Original vehicle radiator with twin fan
- Pressure gauge for the high-pressure and low-pressure side
- Maintenance connections for air conditioning maintenance units
- Webasto ThermoTop V additional water heater (only order number 86070)

Learning objectives:

- Working with maintenance schedules, wiring diagrams, symbols, terminal designations, wires and wiring connections
- Naming mechanical, electrical and electronic components, assembly groups and systems
- Checking and repairing mechanical, electrical and electronic circuits and systems
- Measuring and evaluating electrical variables and signals
- Making use of the possibilities offered by commonly used workshop diagnosis testers
- Processes for timing and in the control circuit
- Functions of sensors and actuators based on the IPO principle (Input-Processing-Output)
- Sequential and selective final control diagnostics, basic actuator settings

Scope of delivery:

Complete, operational and ready-to-use training stand, two pressure gauges, fault circuit, operating manual, technical documentation and electric wiring diagrams

Specifications:

Dimensions: L x W x H 1400 x 800 x 1950 mm
Weight: approx. 150 kg
Electrical connection: 400 V/16 A mains connection



Measuring station

Order-No.

82-83454

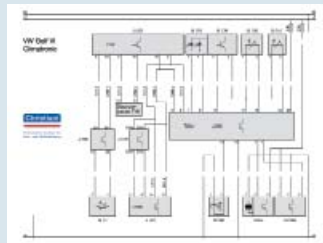

Article

Wiring diagram pad for VW Dual-Zone Climatronic with T20d steering column control unit

Order-No.

82-95029

Wiring diagram pad for VW Dual-Zone Climatronic with T16r steering column control unit

82-95087

Wiring diagram pad for VW Dual-Zone Climatronic with Webasto Thermo Top V standard series additional water heater

82-95088

Article

Functional Model/Training Stand VW Dual-Zone Climatronic

Order-No.

82-77174

VW Dual-Zone Climatronic with Webasto Thermo-Top V standard series additional water heater

Version of the training stand similar to (order number 77174), although with factory-fitted, fully diagnostic-capable Webasto Thermo-Top V additional water heater. The system is programmed via the auxiliary heater fitted and is operated using 95 octane petrol. To this end, a removable 5 litre fuel tank is attached to the system using quick-release fastenings. This makes it easier to fill the tank. Since the additional water heater is NOT emissions-free, it may only be used outdoors or in areas that offer the necessary extraction to comply with legal stipulations.

Article

Functional Model/Training Stand Climatronic Golf 6 with Webasto Thermo Top standard series auxiliary heater

Order-No.

82-86070

Recommended Accessories (optional)

Article

Wiring diagram stand, neutral

Order-No.

82-94910

VW testing box VAG 1598/42

82-86594

VW testing adapter VAG 1598/4

82-89383

VCDS basic kit

82-82251

VCDS pro maxi service case

82-86596

PCAN Interface/ISO adapter with USB connection

82-58053

Commercial Vehicle Technology

Training Stand/Functional Model

EBS 1C Compressed-Air Braking System

The motor vehicle compressed-air braking system consists solely of original components from WABCO. To show the EBS control procedures, the functional model has four electrically driven wheel units for simulation of the front and rear axle. An integrated fault circuit, with 10 practically oriented faults, makes it possible to follow realistic operating situations and practice troubleshooting. The modular system structure allows students to gradually become accustomed to the field of commercial vehicle compressed-air braking systems.

The flexible component connections ensure the greatest possible freedom in designing training situations and action-oriented learning content transfer. The differently coloured compressed-air lines support a clearly structured test set-up. The system has an OBD diagnostic interface for connecting suitable diagnostic systems. Another interface allows connection of up to 14 training measuring stations.

Supplied with four large pressure gauges and original test connections, the test steps of the functional and SP pressure protection

tests can be presented in a logical structure in line with Appendix VIII § 29 of the German road traffic licensing regulations (StVZO).

The original WABCO diagnostic program, WABCO test equipment and WABCO presentation programs are available as enhancements and accessories.

The size has been matched to the size of a conventional 80 cm door. This allows the set-up to be moved around a building without causing problems, allowing it to be used at various locations.

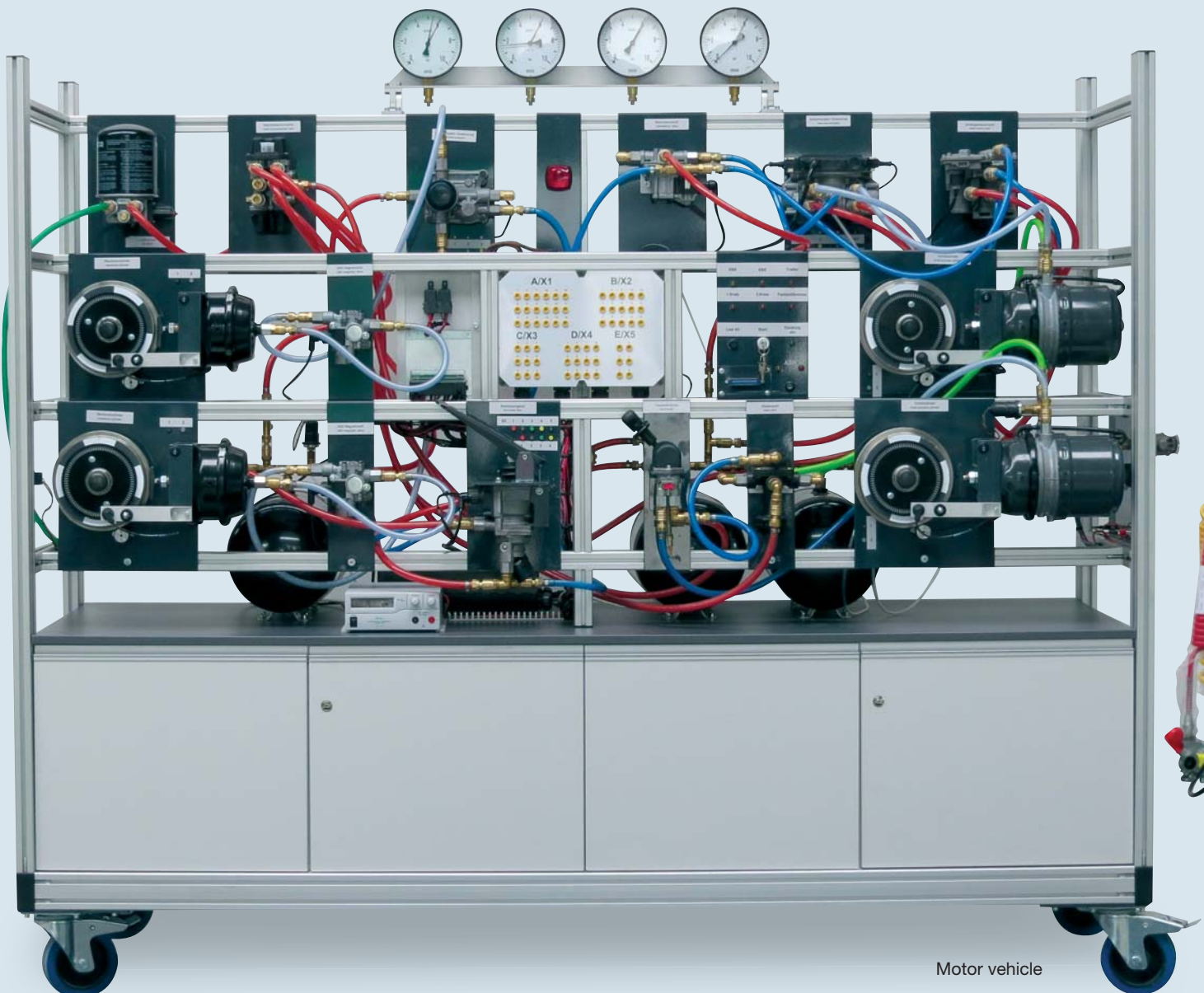

EBS 1C Compressed-Air Braking System

Standard motor vehicle equipment:

- EBS 1C compressed-air braking systems with original WABCO components
- Integrate fault circuit with 10 practical faults
- Measuring points on components with fault circuit
- Four large pressure gauges for functional and pressure protection tests (SP)
- Versatile test connections with T-piece for functional and pressure protection tests (SP)
- OBD diagnostic connection
- Interface for training measuring stations
- Training documentation, basic course on the compressed-air braking system
- Training documentation, EBS, ABS, ECAS

Standard equipment with trailer:

- Supply and brake line with Wendelflex pipes and coupling heads
- Dual-line dual-circuit brake systems as per EG
- EBS electronic brake system
- ECAS electronically controlled air suspension
- Original WABCO trailer diagnostic connection
- Trailer supply cable with EBS connector

Hinged dial gauges, stand fits through all standard size door frames

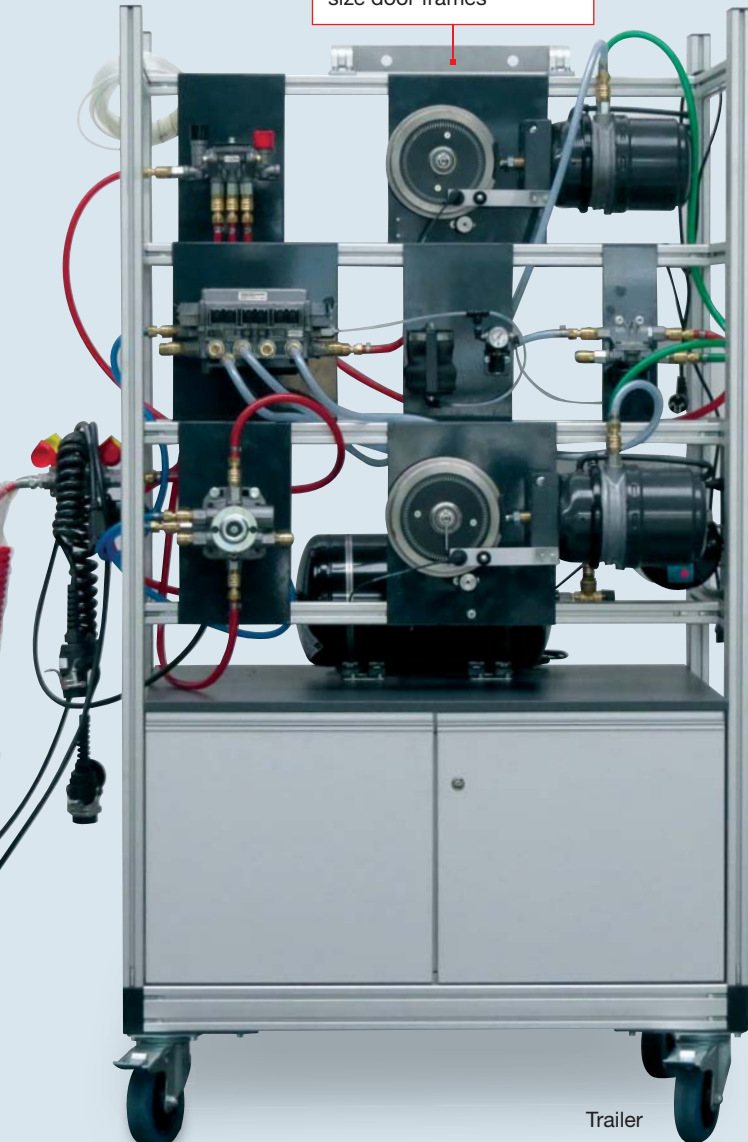

Learning objectives:

- Performing maintenance, diagnostic and repair work on brake systems and networked systems
- Identifying brake systems, analysing the functions and interactions with other systems
- Localising faults in brake systems
- Evaluating the self-diagnostics of electronic braking energy regulation systems and networked systems, linking of control units, analysing the data exchange
- Documenting the measured values, signals and fault protocols
- Making use of the opportunities offered by standard workshop diagnostic and information technology
- Encoding control units, adapting software statuses and checking data communications lines
- Observing manufacturer-specific regulations for the exchange of worn and defective components
- Performing a functional and pressure protection test SP in line with Appendix VIII § 29 of the German road traffic licensing regulations (StVZO)

Scope of delivery:

Ready-to-use and movable functional model, including voltage-stabilised 12 V 60 A switched mode power supply, self-sealing compressed air safety couplings on all components, all required hose connections, datasheets, circuit and hose diagram, manual and operating instructions.

Specifications (motor vehicle):

Dimensions: L x W x H 2400 x 800 x 1970 mm
 Weight: approx. 570 kg
 Electrical connection: 110 V/240 V mains connection
 Compressed-air connection: Compressor with min. 10 bar and sufficient performance (L/min)

Specifications (trailer):

- Dimensions: L x W x H 110 x 800 x 1970 mm
- Weight: approx. 230 kg

Article	Order-No.
Training Stand/Functional Model EBS 1C Compressed-Air Braking System with motor vehicle and trailer	82-77192
Training Stand/Functional Model EBS 1C Compressed-Air Braking System motor vehicle	82-80870
Training Stand/Functional Model EBS 1C Compressed-Air Braking System trailer	82-80871



Our international team is pleased to advice you

INTERNATIONAL NETWORKS & INSTITUTIONS

CONTACT

Markus Milwa
International Affairs
Mobile: + 49 151 261 084 88
Fax: + 49 7531 5801-85
milwa@christiani.de
www.christiani-
international.com



ASIA-PACIFIC

CONTACT

Lisa Kuner
Team Leader Export
Phone: + 49 7531 5801-54
Fax: + 49 7531 5801-85
kuner@christiani.de
www.christiani-
international.com



NORTH AMERICA, MEXICO

CONTACT

Ferdinand Ganser
Export Manager
Mobile: + 49 151 186 177 16
Fax: + 49 7531 5801-85
ganser@christiani.de
www.christiani-
international.com



NEAR-MIDDLE EAST/NORTH AFRICA

CONTACT

Fathi Jamal
Export Manager
Mobile: + 49 151 121 251 47
Fax: + 49 7531 5801-85
jamal@christiani.de
www.christiani-me.com



LATIN AMERICA, SPAIN, PORTUGAL

CONTACT

Maiken Kayser
Export Manager
Phone: + 49 7531 5801-945
Fax: + 49 7531 5801-85
kayser@christiani.de
www.christiani.es



AFRICA, RUSSIA, CENTRAL ASIA

CONTACT

Nadja Parcsami
Export Manager
Phone: + 49 7531 5801-38
Fax: + 49 7531 5801-85
parcsami@christiani.de
www.christiani-
international.com



EUROPE

CONTACT

Sandra Strobel
Export Manager
Phone: + 49 7531 5801-9904
Fax: + 49 7531 5801-85
strobel@christiani.de
www.christiani.eu



Dr.-Ing. Paul Christiani
GmbH & Co. KG
Hermann-Hesse-Weg 2
78464 Konstanz, Germany

Phone: +49 7531 5801-210
Fax: +49 7531 5801-85
E-Mail: info@christiani-tvet.com
www.christiani-tvet.com